



Gas-fired convective air heaters

## **GHIBLI 4 - 5 - 6 ELITE**



# **GAS FIRED CONVECTION HEATERS WITH FAN GHIBLI SERIES Models 4 - 5 - 6**

## **Technical information**

This manual is divided into three sections:

- **SECTION 1 - GENERAL INFORMATION**

It contains all the information relevant to the description of the heaters and their technical features

- **SECTION 2 - TECHNICAL INFORMATION FOR THE INSTALLER**

It contains all the instructions that the technical installer must comply with to ensure effective plant operation

- **SECTION 3 - USER OPERATING AND MAINTENANCE INSTRUCTIONS**

The section is reserved for the user and contains all the information needed to use the appliance correctly and to perform periodic tests

### **Important notes:**

- 1 - To use the appliance correctly and safely, the installer, the user and the service man, must comply with what is indicated in this manual.
- 2 - The word **WARNING!** is followed by information which, because of its importance, must be carefully observed and for which non-compliance may damage the appliance and/or reduce operating safety.
- 3 - The paragraphs written with **bold** characters contain important information, warnings or recommendations which should be carefully considered.
- 4 - The technical data, styling characteristics, components and accessories detailed in this manual are not binding. A2B ACCORRONI E.G. S.r.l. reserves the right to make changes, at any time, that are considered necessary to improve the product.
- 5 - The legal references, standards and technical rules mentioned in this manual are presented merely for the sake of information and should be considered valid as of the date this manual is printed, as indicated on the last page. If new regulations or amendments to current laws go into effect, this will not obligate A2B ACCORRONI E.G. S.r.l. in any way with regard to others.
- 6 - A2B ACCORRONI E.G. S.r.l. is responsible for ensuring that its product conforms to the laws, directives and construction standards in force at the time the product is sold. Knowledge and compliance with legal regulations and standards regarding plant design, installation, operation and maintenance are the exclusive responsibility of the designer, installer and user.

## **SUMMARY**

### **SECTION 1 - GENERAL INFORMATION**

page

1.	<i>PRINCIPAL CHARACTERISTICS</i> .....	4
1.1	Appliance classification .....	4
1.2	Certification - EC marking .....	4
1.3	Functional description .....	4
1.4	Construction characteristics .....	5
1.5	Package contents .....	5
1.6	Accessories supplied on request .....	5
1.7	Application .....	5
1.8	Dimensions .....	6
1.9	Wiring diagram .....	7
1.10	Technical data table .....	8
1.11	Exploded view .....	9

2.	<i>CONTROL AND SAFETY DEVICES</i> .....	12
2.1	Gas controller .....	12
2.2	Gas unit .....	12
2.3	Fan thermostat .....	12
2.4	Safety thermostat .....	12

## **SECTION 2 - TECHNICAL INFORMATION FOR THE INSTALLER**

3.	<i>PRECAUTIONS</i> .....	13
3.1	Gas safety regulations .....	13
3.2	Related documents .....	13
3.3	Transport and handling .....	13
3.4	Data check .....	13
3.5	Using the instructions .....	13
4.	<i>INSTALLATION</i> .....	13
4.1	Positioning instructions .....	13
4.2	Air intake and flue exhaust ducts .....	14
4.3	Outside positioning of the flue gas exhaust terminal .....	15
4.4	Installation operations .....	15
5.	<i>START-UP</i> .....	18
5.1	Tests .....	18
5.2	Ignition .....	19
5.3	Useful information .....	19
6.	<i>GAS TYPE CHANGE</i> .....	20
6.1	Switching from gas in the second group to gas in the third group .....	20
6.2	Switching from gas in the third group to gas in the second group .....	20
7.	<i>OPERATING DEFECTS</i> .....	21
7.1	Preliminary tests .....	21
7.2	Possible defects .....	21
8.	<i>REPLACING PARTS</i> .....	23
8.1	Control equipment .....	23
8.2	Fuse .....	23
8.3	Gas solenoid valves .....	23
8.4	Convection fan control thermostat .....	23
8.5	Safety limit thermostat .....	23
8.6	Electrodes .....	24
8.7	Flue exhaust fan .....	24
8.8	Convection fan .....	24
9.	<i>PERIODIC MAINTENANCE OPERATIONS</i> .....	25
9.1	User information .....	25
9.2	Yearly inspection .....	25

## **SECTION 3 - USER OPERATING AND MAINTENANCE INSTRUCTIONS**

10.	<i>START-UP</i> .....	26
10.1	First firing and testing .....	26
10.2	Tests .....	26
10.3	Ignition .....	26
10.4	Shutdown .....	26
11.	<i>APPLIANCE MAINTENANCE</i> .....	27
11.1	Routine maintenance to be performed by the user .....	27
11.2	Annual air heater inspection .....	27

## FIGURE SUMMARY

Fig. no.		page
1	Dimensions .....	6
2	Wiring Diagram .....	- Ghibli Model 4 ..... 7
3	Wiring Diagram .....	- Ghibli Model 5 ..... 7
4	Wiring Diagram .....	- Ghibli Model 6 ..... 8
5	Exploded View .....	- Ghibli Model 4 ..... 9
6	Exploded View .....	- Ghibli Model 5 - 6 ..... 10
7	Gas controller .....	12
8	Fan thermostat .....	12
9	Safety thermostat .....	12
10	Positioning .....	14
11	Minimum maintenance distances .....	14
12	Type C <sub>12</sub> installation .....	14
13	Type C <sub>52</sub> installation .....	15
14	Terminal protection grille .....	15
15	Intake/exhaust duct .....	16
16	Solution with duct doubling device .....	16
17	Location of the doubling device in the wall .....	16
18	Coupling with the doubling device .....	16
19	Power supply cable connection .....	18
20	Connecting more than one unit with a single external timer .....	18
21	Control panel .....	19
22	Gas unit .....	20
23	Standard gas change .....	21
24	Control equipment replacement .....	23
25	Gas unit coil replacement .....	23
26	Fan thermostat replacement .....	23
27	Safety thermostat replacement .....	24
28	Electrode positioning .....	24
29	Flue exhaust replacement .....	24
30	Fan replacement .....	- Ghibli Model 4 ..... 24
31	Fan replacement .....	- Ghibli Model 5 - 6 ..... 25
32	Cleaning the appliance .....	- Ghibli Model 4 ..... 25
33	Control panel .....	26

# SECTION 1 - GENERAL INFORMATION

## **1. PRINCIPAL CHARACTERISTICS**

### **1.1 APPLIANCE CLASSIFICATION**

These appliance are defined as "Independent gas-fired convection heaters incorporating a fan to assist transportation of combustion air and flue gases".

In addition, they are classified according to harmonised European standards EN 437 and EN 1266 into:

**category** - according to the types of gas, at the different supply pressures, that they can use;

**type** - according to the possible methods to exhaust the combustion productions (*see also 4.2.1*).

#### **1) Category II<sub>2H3+</sub>**

the heater is suitable to use gas that belongs to two families. The atmospheric burner can be fed with gas from the second group (natural gas - group H) and gas from the third group (butane and propane at the two pressure ratings 28-30 and 37 mbar)

#### **2) Type C<sub>12</sub>**

The combustion circuit is sealed with respect to the environment in which it is installed and the combustion air supply and combustion product exhaust lines are connected outside the room by means of flues which pass directly through the outside wall of the room.

#### **3) Type C<sub>52</sub>**

The combustion circuit is hermetically sealed with respect to the environment in which it is installed and the combustion air supply and combustion product exhaust lines are connected outside the room by means of separate ducts with terminals which need not necessarily be adjacent to each other. (In this case, a special accessory shall be used which is supplied on request).

### **1.2 CERTIFICATION - EC MARKING**

The Ghibli air heaters, as previously described and classified, have obtained the "CE type test certificate" in conformity with EEC Directive 90/396 and with reference to the harmonised European standard EN 1266. Attaching the CE marking shown below also guarantees that the appliance conforms with EEC directive 2006/95 ("Low voltage") through the harmonised standard

EN 60335-1 and EEC directive 2004/108 ("Electromagnetic compatibility") through the standards EN 50081-1 and 50082-1.



It is important to point out that, to protect the end user, attaching the CE marking means that the manufacturer must submit a declaration of conformity for the entire line of products with the certified characteristics and performance ratings. This is possible through the use, by the manufacturer, of a Quality Assurance system. The efficiency of that system is controlled by the Organisation which issued the certification.

### **1.3 FUNCTIONAL DESCRIPTION**

The Ghibli air heater consists basically of a heat exchanger unit which exchanges heat between the combustion products of a gas burner and the air flow delivered by a fan.

The technology used to build the burner also ensures very low emission of polluting NOx (nitrogen oxides) for this category of appliance.

The fan takes in the room air which is then heated as it passes through the heat exchanger. The warm air is discharged directly into the environment through the grille located at the top of the appliance.

Fan operation is controlled by a thermostat: to prevent cold air from entering the environment. The fan begins operating shortly after the burner has ignited. The fan runs for a short time after the burner is extinguished, to allow the exchanger to cool off gradually.

In case of malfunction or if the fan does not turn on and the exchanger overheats, a safety thermostat trips and cuts off the gas flow to the burner.

The combustion products are exhausted outdoors by a centrifugal fan installed after the hermetically sealed combustion circuit. The combustion chamber always has a lower pressure with respect to the environment, thus providing an additional safety feature.

Air heater operation is controlled by the built-in room thermostat and by a digital timer that may be supplied on request.

#### **1.4 CONSTRUCTION CHARACTERISTICS**

The casing is built with ivory-coloured, epoxy-powder painted steel plate, with sides made with black, heat-resistant nylon. The two air intake and delivery grilles are located, respectively, at the bottom and at the top of the casing.

The control panel is located on the front of the appliance. This panel includes the following:

- on/off switch
- convection fan speed switch (models 5 and 6)
- reset switch for the burner control device
- lockout led
- heat request led
- room thermostat regulation dial

The rear of the appliance includes the following:

- the connector for the combustion air inlet and combustion product exhaust ducts
- the holes to attach the appliance to the wall
- the entry with cable gland for the air heater electric power supply

The following is installed inside the appliance:

- the combustion chamber and the finned heat exchanger with flue gas exhaust fan located after the heat exchanger.
- the atmospheric burner with ignition electrode and flame detection electrode
- a tangential convection fan for Ghibli model 4 and a centrifugal type with double impeller and central motor for Ghibli models 5 and 6
- the fan control thermostat and safety thermostat
- the electric board including the burner control device, the gas unit, the room thermostat and related wiring

#### **1.5 PACKAGE CONTENTS**

The air heater is shipped with cardboard packing with two polystyrene foam protection shells which also contain:

- the intake and exhaust duct for walls up to 40 cm, complete with connector flange, ceramic fibre gasket, attachment screws and wind protection terminal
- gas conversion kit with label.
- the gas on-off valve
- a screwdriver to disassemble the casing
- this installation and servicing technical information manual as well as warranty documents

#### **1.6 ACCESSORIES SUPPLIED ON REQUEST**

In addition to the material described above, the following accessories can also be supplied on request:

- intake and exhaust duct, 100 cm
- intake and exhaust doubling device including terminals, to be used with separate ducts Ø 60 mm, rigid or bendable (see point 4.2.1)
- protection grille for standard terminal
- digital timer kit

#### **1.7 APPLICATION**

The Ghibli gas heater is an independent appliance designed to heat individual rooms. This design solution is a good alternative to traditional equipment, since it does not involve costly installation work and allows heat to be managed in a personalised manner, room by room, only when it is needed. The Ghibli gas heater is ideal for single-family dwellings, vacation homes, offices, stores, laboratories.

It is particularly suitable for restructuring projects, where a traditional system would require major masonry work or involve exorbitant costs. The Ghibli gas heater can also be added to an existing system.

**WARNING! It is important to verify that the design and installation conform with current standards.**

## 1.8 DIMENSIONI E INGOMBRI

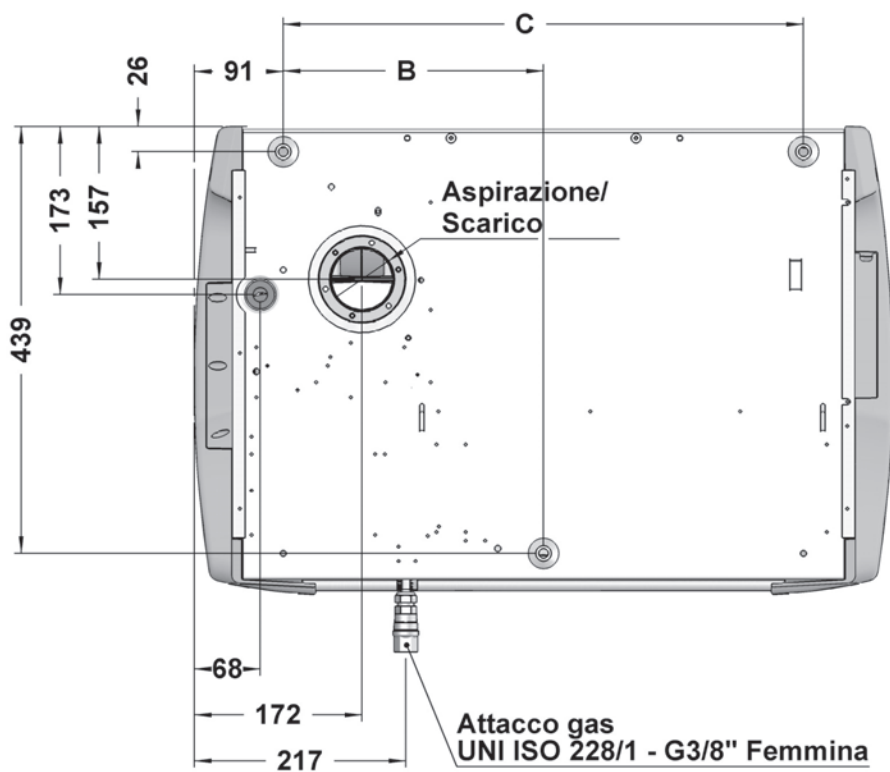
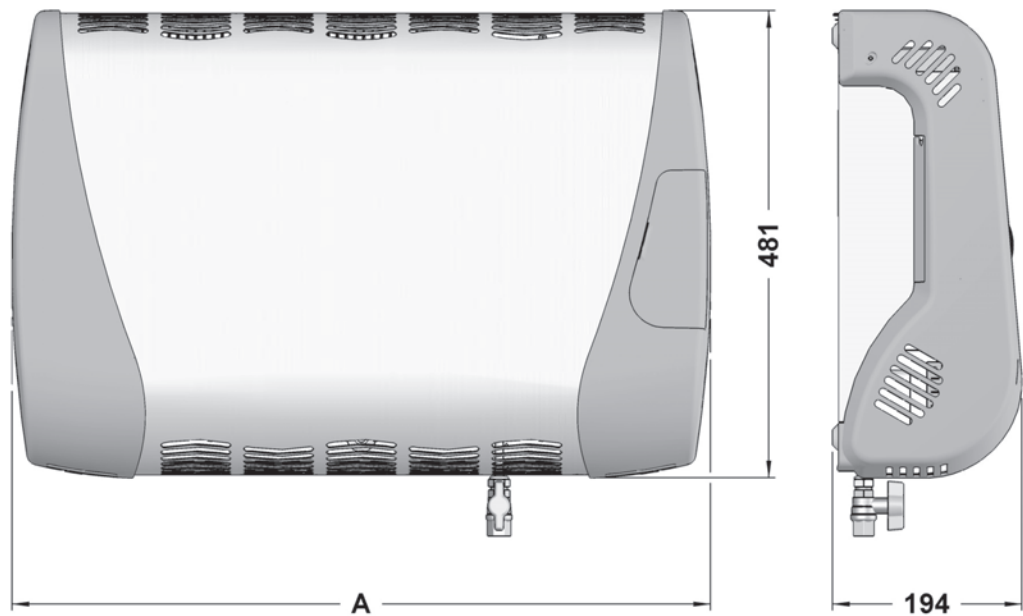

	A	B	C	Aspir./Scar.	Gas
Ghibli 4	717	267	534	Ø 65	G 3/8"
Ghibli 5 - 6	807	366	624	Ø 65	G 3/8"

### 1.9 WIRING DIAGRAM - Ghibli Model 4

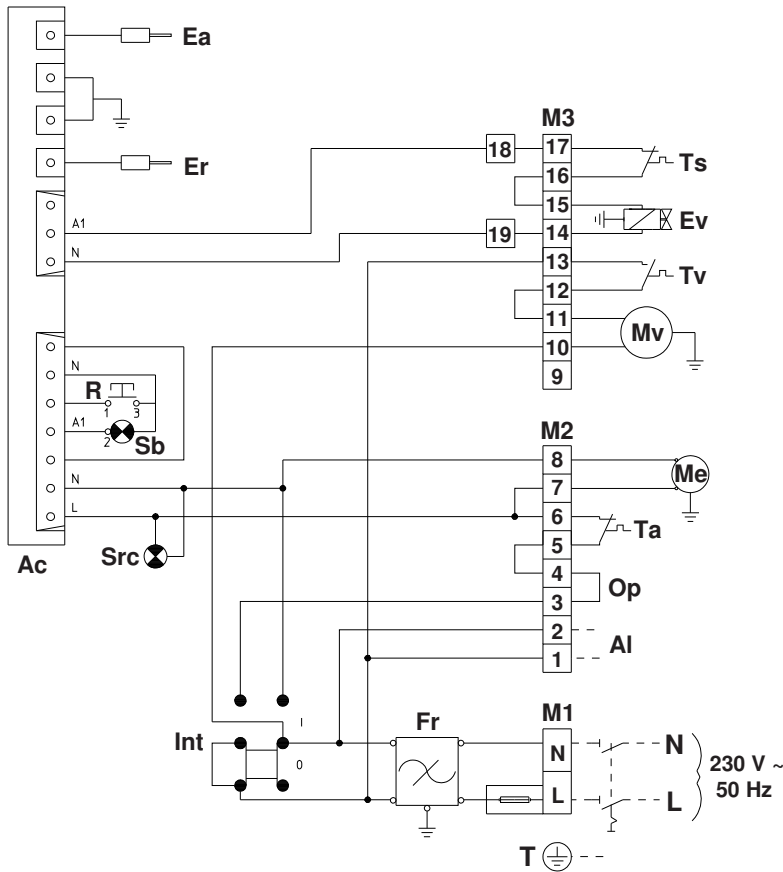

- Al** = External auxiliaries supply
- Ac** = Control equipment
- Ea** = Ignition electrode
- Er** = Flame detection electrode
- Ev** = Gas solenoid valve
- Fr** = RFI filter
- Int** = On-Off switch
- M1-2-3** = Connection terminal boards
- Me** = Flue gas exhaust motor
- Mv** = Fan motor
- Op** = Bridge for auxiliaries (i.e.: timer)
- R** = Reset button
- Sb** = Lockout signal
- Src** = Heat request signal
- T** = Earth connection
- Ta** = Room thermostat
- Ts** = Safety thermostat
- Tv** = Fan thermostat
- = Fuse, 2A
- = Connection to be made
- = Series connection

**Warning:**

- Power should be supplied to the heater via a switch with contact opening of at least 3 mm.
- Observe the correct phase-neutral polarity when connecting the single-phase, 230 V ~ 50 Hz power supply.

**Fig. 2**

### 1.9 WIRING DIAGRAM - Ghibli Model 5

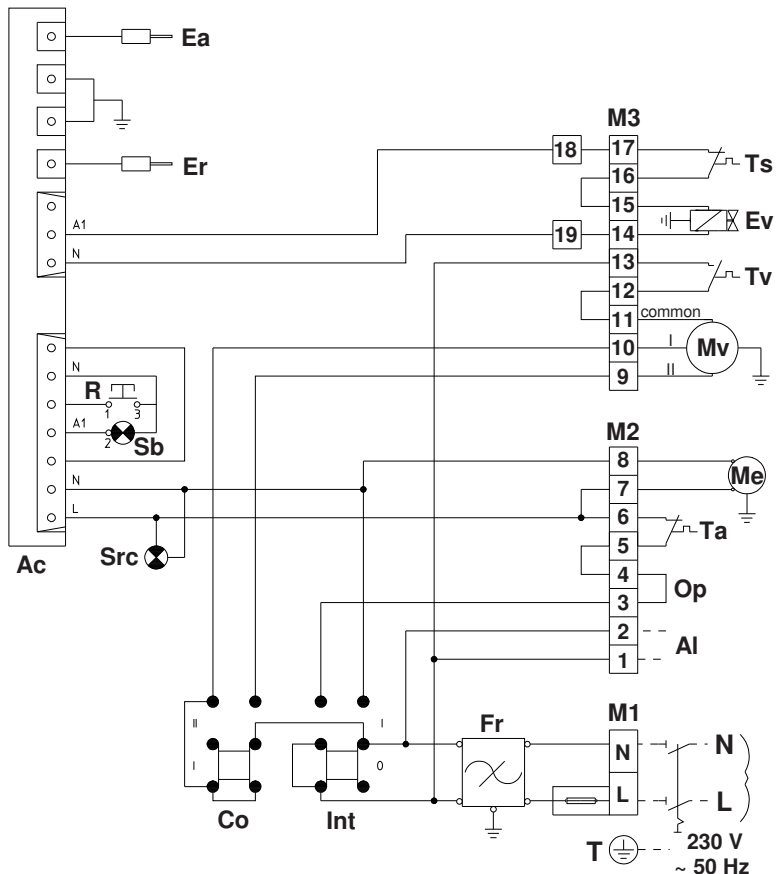

- Al** = External auxiliaries supply
- Ac** = Control equipment
- Co** = Fan speed switch
- Ea** = Ignition electrode
- Er** = Flame detection electrode
- Ev** = Gas solenoid valve
- Fr** = RFI filter
- Int** = On-Off switch
- M1-2-3** = Connection terminal boards
- Me** = Flue gas exhaust motor
- Mv** = Fan motor
- Op** = Bridge for auxiliaries (i.e.: timer)
- R** = Reset button
- Sb** = Lockout signal
- Src** = Heat request signal
- T** = Earth connection
- Ta** = Room thermostat
- Ts** = Safety thermostat
- Tv** = Fan thermostat
- = Fuse, 2A
- = Connection to be made
- = Series connection

**Warning:**

- Power should be supplied to the heater via a switch with contact opening of at least 3 mm.
- Observe the correct phase-neutral polarity when connecting the single-phase, 230 V ~ 50 Hz power supply.

Fan motor connections	2 speed motor	3 speed motor
Max. speed	II	
Med. speed		II
Min. speed	I	I

**Fig. 3**



## 1.9 WIRING DIAGRAM - Ghibli Model 6

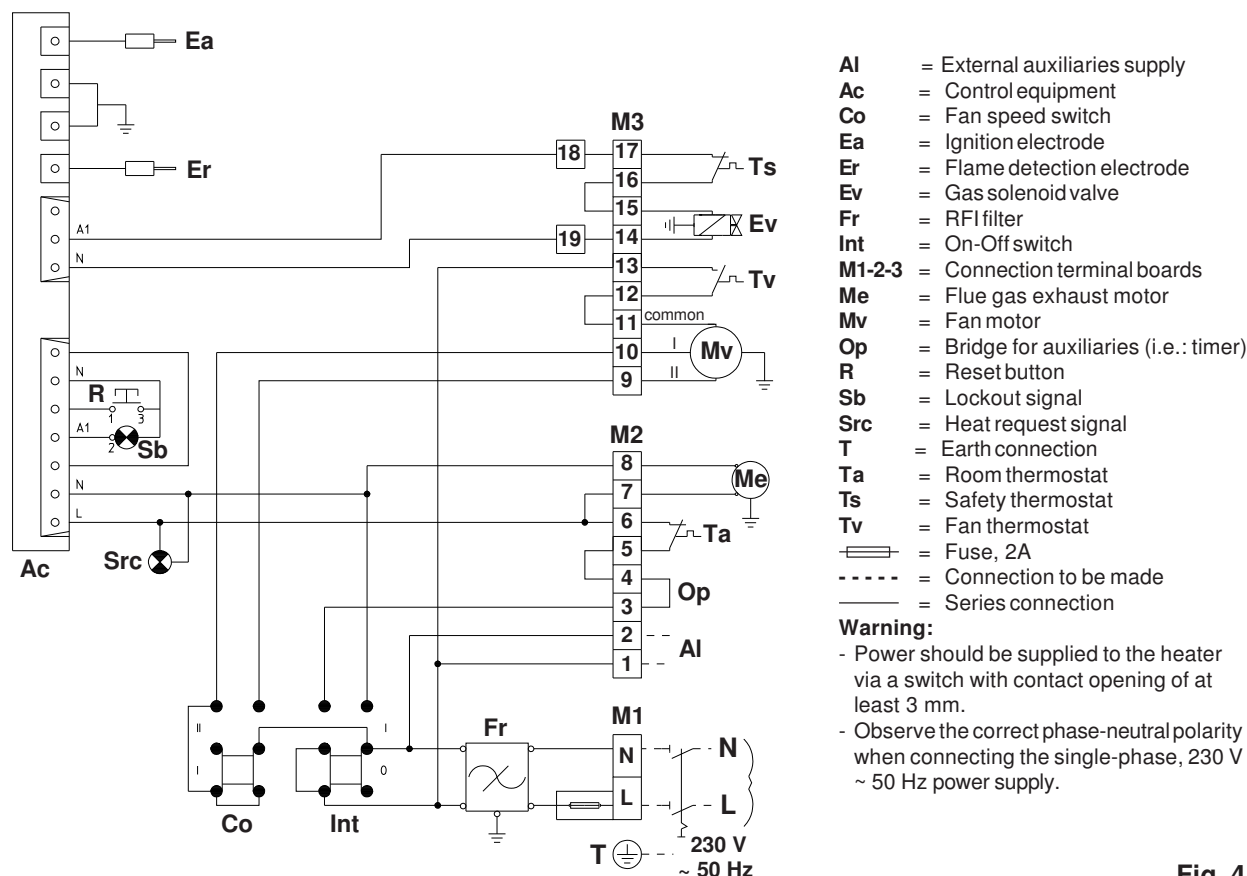

Fig. 4

1.10 TECHNICAL DATA TABLE		Units	Ghibli 4	Ghibli 5	Ghibli 6
Heat input (H <sub>i</sub> )		kW	3,72	4,83	5,52
		kcal/h	3.200	4.150	4.750
Heat output (H <sub>e</sub> )		kW	3,35	4,37	4,91
		kcal/h	2.880	3.760	4.220
Gas consumption (15 °C - 1.013 mbar)	Natural gas G20	mc/h	0,39	0,51	0,58
	Butane G30	kg/h	0,29	0,38	0,44
	Propane G31	kg/h	0,29	0,37	0,43
Burner pressure (15 °C - 1.013 mbar)	G20 p 20 mbar	mbar	11,5	11,5	11,5
	G30 p 28-30 mbar	mbar	27,8-29,8	27,7-29,8	27,7-29,8
	G31 p 37 mbar	mbar	36,5	36,5	36,5
Injector size	G20	mm	1,70	1,90	2,05
	G30 / G31	mm	1,00	1,10	1,15
Air delivery	Min. speed	m <sup>3</sup> /h	110	180	240
	Max. speed	m <sup>3</sup> /h	-	240	300
Gas service connection		"	G 3/8		
Air supply / Flue exhaust diameter		mm	65		
Fuse		A	2		
Electrical supply			230 V ~ / 1 / 50 Hz		
Electric power		W	47	80	102
Net weight		kg	21	27	27

1.11 EXPLODED VIEW - Model Ghibli 4

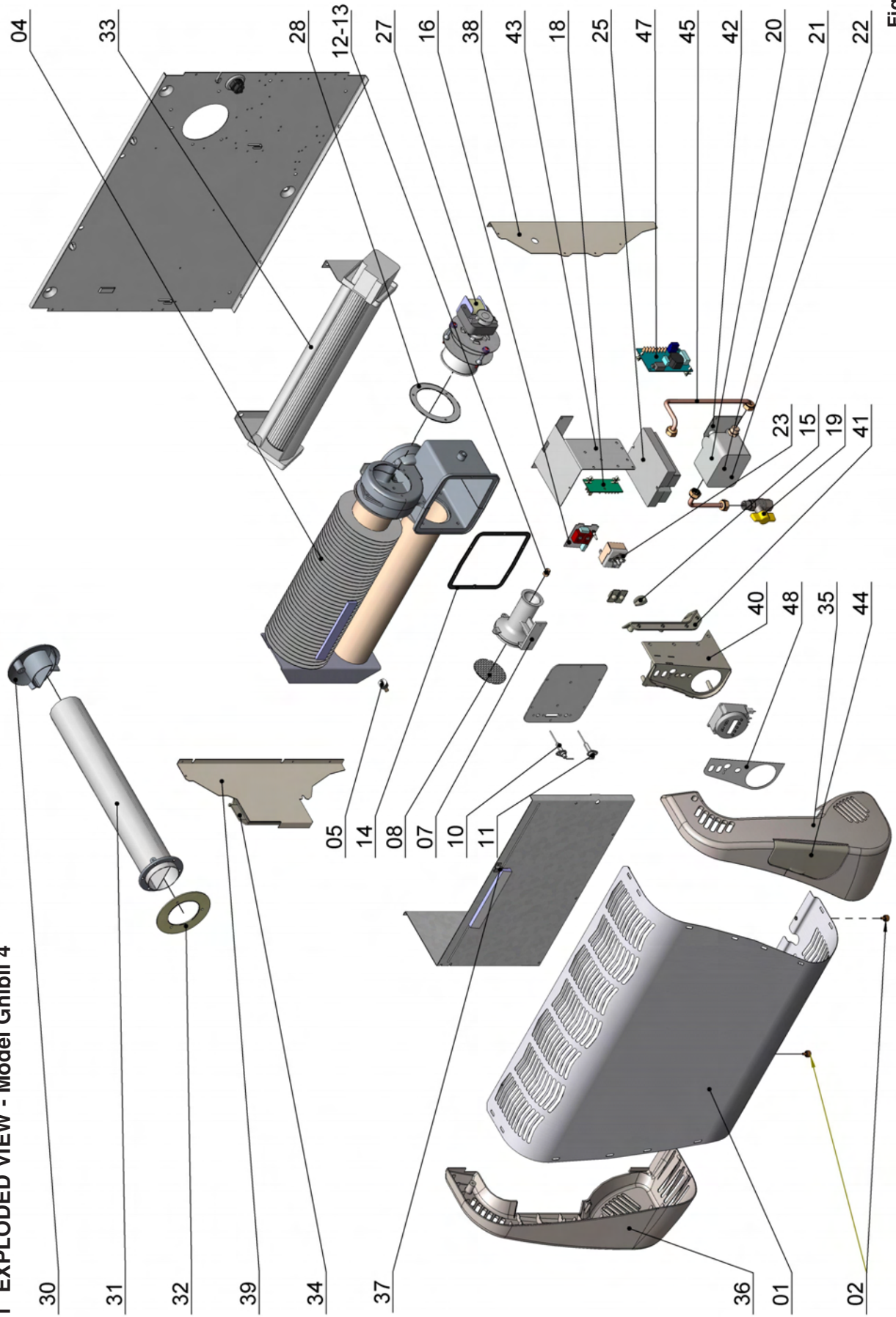

Fig. 5

1.11 EXPLODED VIEW - Models Ghibli 5 and 6

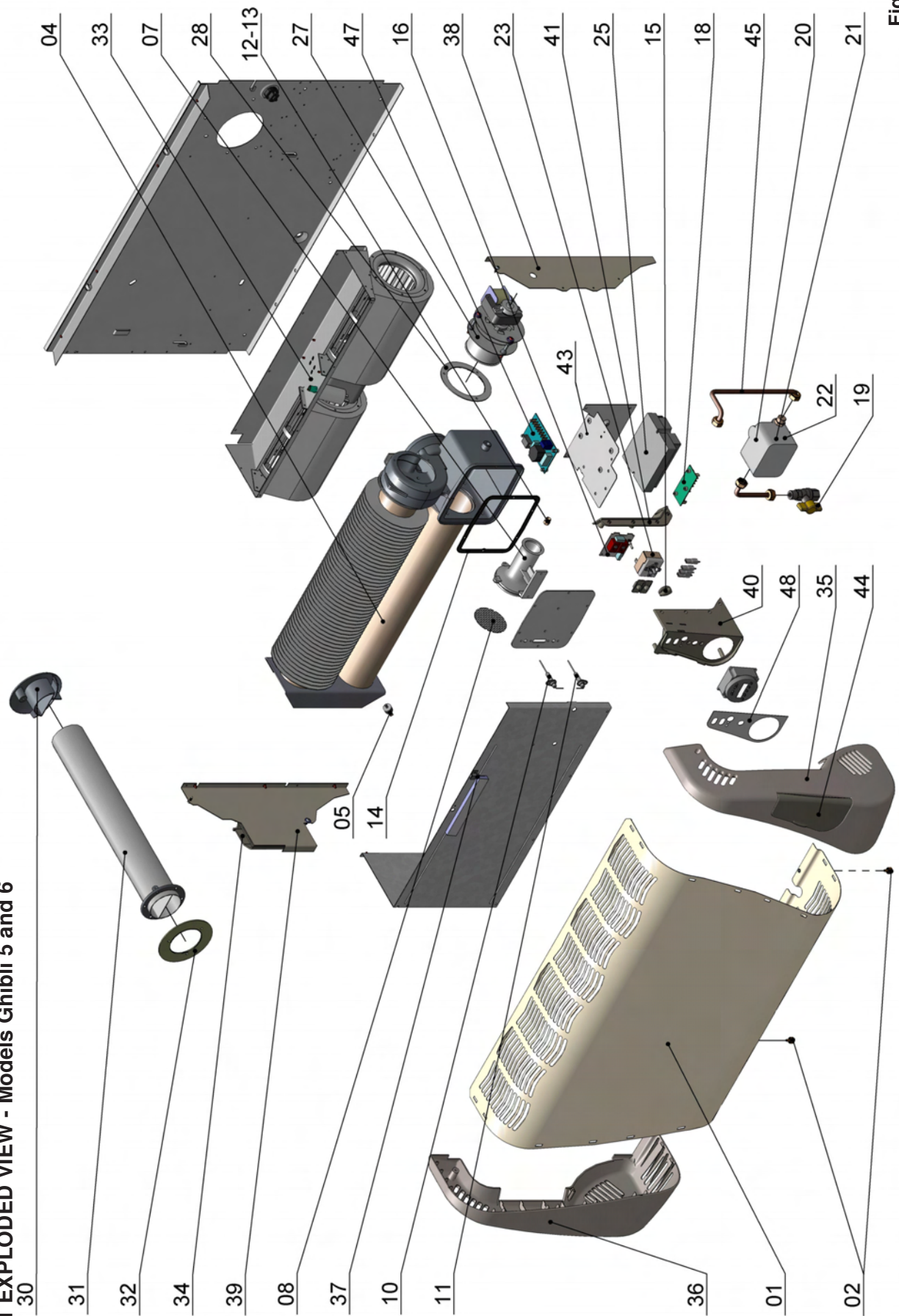

Fig. 6

**Legend of components Ghibli 4 (see fig. 5)**

Pos	Codice	Description
01	45610001	Casing Ghibli 5/6 Elite
02	45810002	Screw for casing fixing
04	45610004	Heat exchanger Ghibli 4
05	40170018	Fan thermostat
07	45610008	Burner Ghibli 4
08	45610009	Burner Disk Ghibli
10	45960007	Flame detection electrode
11	45960008	Ignition electrode
11	45610012	Gas injector MET 1.70
12	45610313	Gas injector LPG 0.95
14	45610014	Burner chamber gasket
15	45970012	Knob room thermostat
16	45620015	Commands electrical board
18	45620017	Electric supply connection board
19	45810021	Gas tap
20	45960033	Gas valve
21	45960034	Valve rectifier bridge
22	45960035	Spool gas valve
23	45970020	Room thermostat
25	45960216	Control box
27	45620026	Flue gas exhaust fan
28	45610032	Exchanger/exhauster gasket
30	45610034	Intake/exhaust terminal
31	45610035	Intake/exhaust duct
32	45610036	Duct attachment gasket
33	45610037	Tangential fan
34	45880506	Tank of humidity
35	45880501	Plastic side dx Ghibli elite
36	45880502	Plastic side sx Ghibli elite
37	45610003	Safety thermostat
38	45650211	Plate side dx Ghibli elite
39	45650212	Plate side sx Ghibli elite
40	45880503	Fixing plate side A Ghibli elite
41	45880504	Fixing plate side B Ghibli elite
42	45652522	Gas valve plate Ghibli elite
43	45652523	Plate for control box Ghibli elite
44	45880505	Door control Ghibli elite
45	45611601	Gas supply pipe
47	45970011	Internal electric wiring board
48	45619501	Stricker plate of control panel Ghibli 4 elite
<b>(*) Components missing in the design</b>		
*	45610038	Bronze friction bearing
*	45960036	Kit of gas valve connection

**Legend of components Ghibli 5 and 6 (see fig.6)**

Pos	Code	description
01	45660001	Casing Ghibli 5/6 Elite
02	45810002	Screw for casing fixing
04	45710004	Heat exchanger Ghibli 5/6 Elite
05	40170018	Fan thermostat
07	45660008	Complete burner Ghibli 5/6
08	45710009	Burner Disk Ghibli 5/6
10	45960007	Flame detection electrode
11	45960008	Ignition electrode
12	45660013	Gas injector MET 1.90
13	45660014	Gas injector GPL 1.10
14	45610014	Burner chamber gasket
15	45970012	Knob room thermostat
16	45670016	Commands electrical board
18	45620017	Electric supply connection board
19	45810021	Gas tap
20	45960033	Gas valve
21	45960034	Valve rectifier bridge
22	45960035	Spool gas valve
23	45970020	Room thermostat
25	45960216	Control box
27	45670027	Flue gas exhaust fan
28	45610032	Exchanger/exhauster gasket
30	45610034	Intake/exhaust terminal
31	45610035	Intake/exhaust duct
32	45610036	Duct attachment gasket
33	45710039	Centrifugal fan
34	45880506	Tank of humidity
35	45880501	Plastic side dx Ghibli elite
36	45880502	Plastic side sx Ghibli elite
37	45610003	Safety thermostat
38	45650211	Plate side dx Ghibli elite
39	45650212	Plate side sx Ghibli elite
40	45880503	Fixing plate side A Ghibli elite
41	45880504	Fixing plate side B Ghibli elite
43	45652523	Plate for control box Ghibli elite
44	45880505	Door control Ghibli elite
45	45611601	Gas supply pipe
47	45970011	Internal electric wiring board
48	45719501	Stricker plate of control panel Ghibli 4 elite
<b>(*) Components missing in the design</b>		
*	45960036	Kit of gas valve connection
*	45652522	Gas valve plate Ghibli elite

## **2. CONTROL AND SAFETY DEVICES**

### **2.1 GAS CONTROLLER**

This device is housed in a heat-resistant and shockproof plastic enclosure and is mounted on the air heater electric board (*fig. 7*).

The control device operates on the ionisation flame detection principle, using a special probe on the burner.

**The detection circuit must be fed with single-phase 230 V ~ 50 Hz mains voltage. The circuit is sensitive to the phase-neutral polarity. If this is reversed, the device will lock out within the safety time, even if the flame has a regular shape (for special cases consult our Technical Office).**

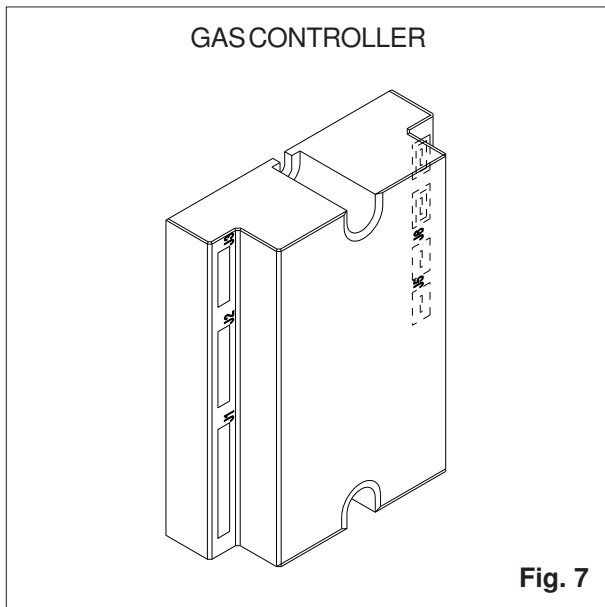

**Fig. 7**

### **2.2 GAS VALVE**

The gas valve includes two, direct operation solenoid valves with class B closing devices (maximum pressure 50 mbar) and a pressure regulator. The die-cast aluminium casing is equipped with 3/8 RP threaded gas inlet and outlet connections and two inlet and outlet pressure test points. The gas valve is also equipped with an inlet filter (*fig. 22*).

### **2.3 FAN THERMOSTAT**

This thermostat controls fan operation, making it start when the exchanger has reached the rated operating temperature and stopping it when the exchanger has adequately cooled. The thermostat is attached to a threaded support, located on the exchanger (*fig. 8*).

### **2.4 SAFETY THERMOSTAT**

The thermostat is designed to interrupt burner operation when the air temperature in the air heater reaches a set value, i.e. when the exchanger overheats due to insufficient air flow or a fan malfunction. The thermostat enclosure uses a special support to attach to the front shield of the appliance (*fig. 9*).

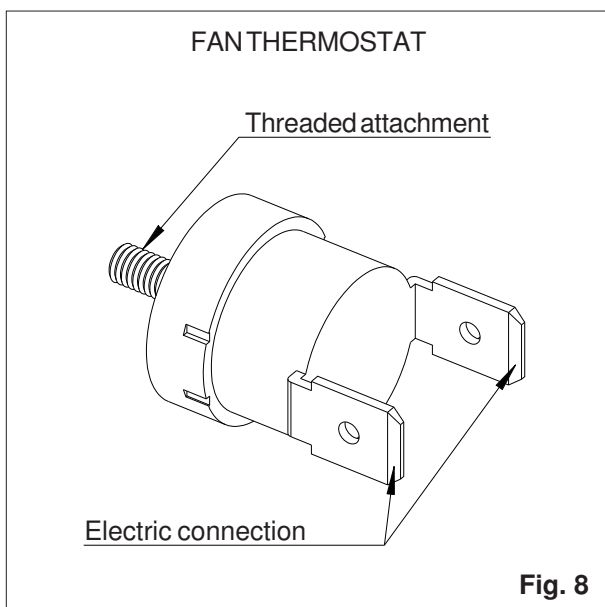

**Fig. 8**

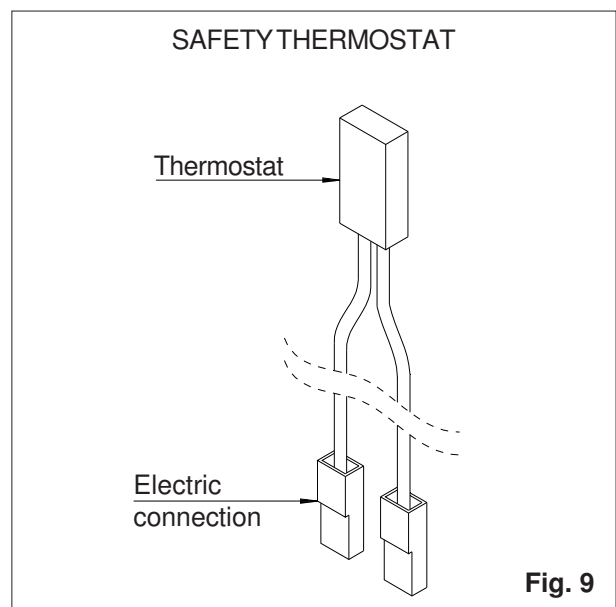

**Fig. 9**

## SECTION 2

# TECHNICAL INFORMATION FOR THE INSTALLER

### **3. PRECAUTIONS**

#### **3.1 GAS SAFETY REGULATIONS**

The law requires all gas appliances to be installed by competent persons in accordance with the regulations. Failure to install appliances correctly may lead to prosecution. It is in your own interests and that of safety to ensure compliance with the law.

#### **3.2 RELATED DOCUMENTS**

Notwithstanding their limited scope, the appliances should be installed in accordance with the relevant provisions of the following regulations:

##### **UNITED KINGDOM**

Gas Safety (Installation and Use) Regulations 1984 and BS 6891: 1988. Due account should be taken of any obligations arising from the Health and Safety at Work etc Act 1974, the current Building Regulations, the current I.E.E. Regulations and other relevant codes of practice.

##### **IRELAND**

I.S.3212: 1987, ICP 4, I.S.327. Due account should be taken of any obligations arising from the current Building Regulations, the current I.E.E. Regulations and other relevant codes of practice.

#### **3.3 TRANSPORT AND HANDLING**

The air heater is supplied with standard cardboard packing with two polystyrene foam shells. The packed appliance can be handled by hand or with a fork-lift truck, making sure to observe the instructions reported on the box indicated by the special graphic symbols.

When delivered, check that no visible damage on the packing and/or on the appliance has occurred during transport. If damage is noted, immediately submit a claim to the shipping agent.

When removing the air heater from the packing, do not damage the cardboard. The assembly template to be used to make the holes on the wall in the room is printed on that cardboard. Check that the packing includes the appliance but also all the parts indicated in point 1.5. Place the material and the documents in a protected area.

#### **3.4 DATA CHECK**

Check that the heater and its technical characteristics match what is indicated by the drawings or other documents.

The type of gas for which the heater has been designed and the supply pressure are found on the exterior of the packing and on a special label located on the inside of the appliance.

**WARNING!** If the type gas for which the appliance has been designed is different from the one being used, the conversion operation must be carried out by skilled technical personnel.

#### **3.5 USING THE INSTRUCTIONS**

**WARNING!** When installing or working on the appliance, comply with all the instructions given in this manual. Changes to any type of connection and non-compliance with these instructions will immediately invalidate the warranty and release the manufacturer from all responsibilities.

### **4. INSTALLATION**

#### **4.1 POSITIONING INSTRUCTIONS**

Before carrying out any installation operations, make sure that the following conditions are satisfied regarding the position where the air heater will be installed:

a) the appliance with standard accessories, must be installed on an external wall to ensure that it operates correctly.

The appliance can also be installed on other walls by using a special kit which splits the flue from the air intake. This is known as a doubling device (*see point 4.2.1*).

b) it must be possible to provide a gas supply to the selected point as well as a single-phase 230 Volts ~ 50 Hz power supply line

c) the position must be suitable to distribute the air correctly into the room and the air flow should not be obstructed by obstacles such as furniture or drapes

d) the appliance must be installed at a minimum of 10 cm from the floor so that the convection fan can take in air correctly and thus ensure optimal circulation of air on the exchanger. Do not install the base of the appliance at a height of more than 50 cm from the floor, since this would lead to a non-uniform distribution of the warm air and thus waste fuel

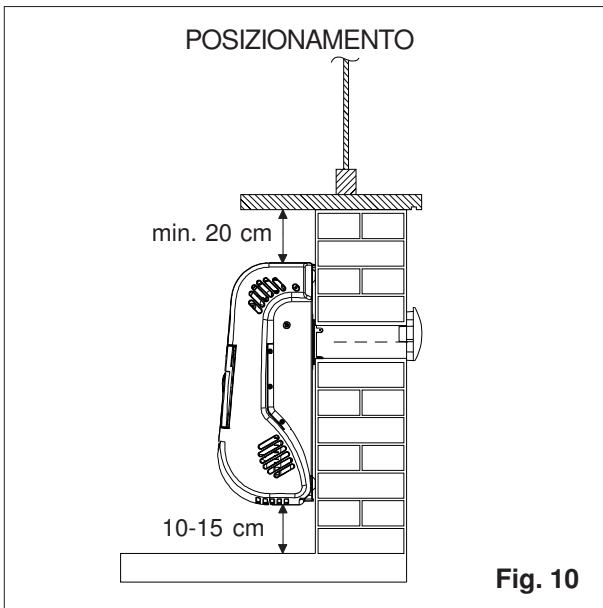

Fig. 10

e) if the appliance is installed under a window or under a shelf, make sure that the sill or the shelf does not obstruct the flow of warm air; it is recommended that a distance of at least 20 cm is maintained. For this reason and to make maintenance easier, the air heater should not be installed inside niches or in positions where it is difficult to access. The clearances indicated in *fig. 11* should be observed.

#### 4.2 AIR INTAKE AND FLUE EXHAUST DUCTS

**WARNING!** The material used to build the external wall and any covering (wood, plastic) must not be sensitive to the heat generated by the flue gas exhaust duct. If it is heat

sensitive, the passage hole must be protected with insulation that insulates the wall or the covering.

##### 4.2.1 Type definition

As already mentioned in point 1.1, the Ghibli air heater can be installed with different configurations of the air intake and combustion product exhaust duct(s) and these different solutions constitute the definition of "type" according to the current standards:

##### - Type C<sub>12</sub> (standard supply)

The combustion circuit is hermetically sealed with respect to the environment in which the air heater is installed. The intake/exhaust duct passes directly through the external wall of the room. This is the standard configuration supplied (*fig. 12*).

##### - Type C<sub>52</sub> (with accessories on request)

The combustion circuit is sealed with respect to the environment in which the air heater is installed. The ducts are separated and both are connected to the outdoors, but their terminals need not be adjacent to each other (*fig. 13*).

**WARNING!** Also in the second solution (Type C<sub>52</sub>), the intake and exhaust ducts, including the relative accessories, are considered by the standards to be integral parts of the air heater. Therefore, they must be requested from the manufacturer.

In both the cases described above the length of the ducts must always respect the limits indicated in the next point.

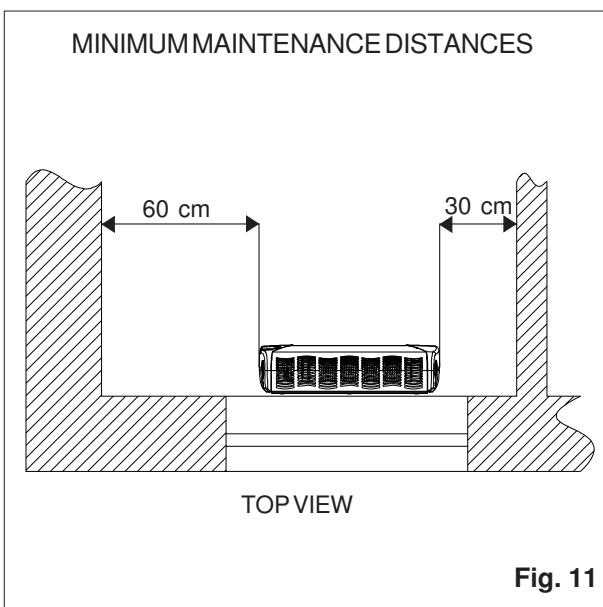

Fig. 11

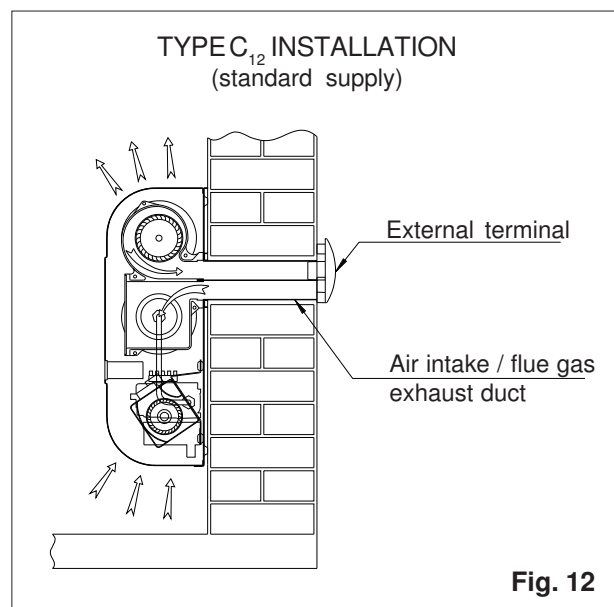
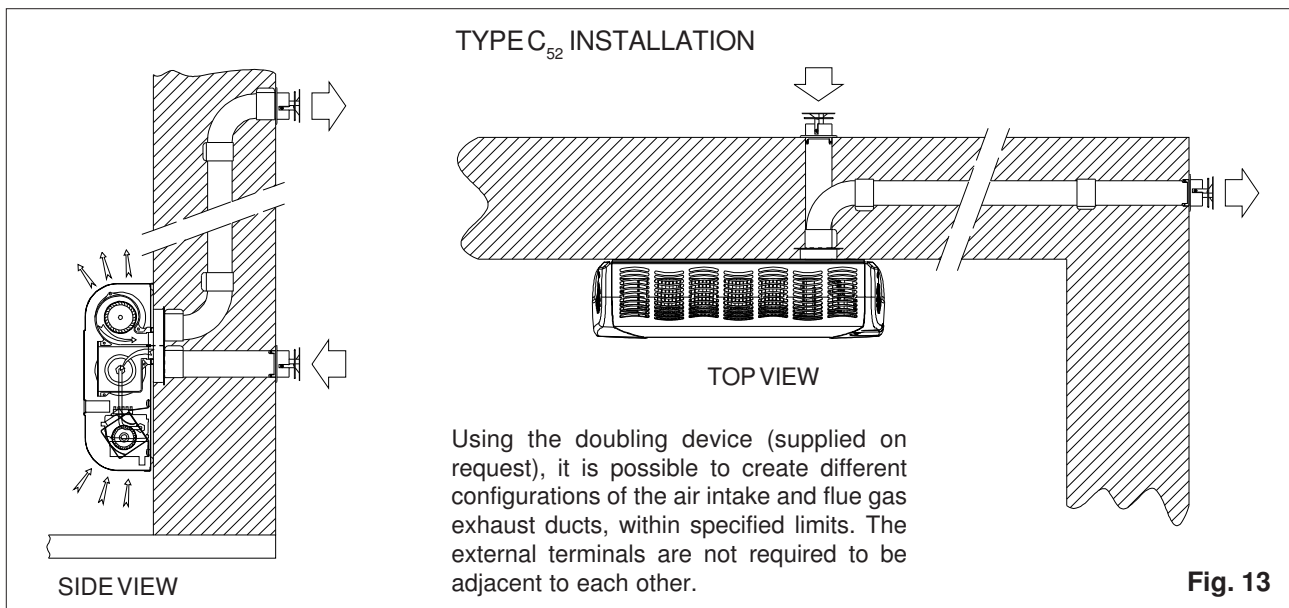

Fig. 12



#### 4.2.2 Duct length limits

If the duct passes directly through the external wall, and if that wall has a thickness of more than 40 cm, an intake/exhaust duct with a length of 1 metre can be supplied on request. If the appliance is installed with separated ducts, using the special accessory, the length of the ducts must not be greater than 6 metres, considered as the sum of the layout of both ducts (for example: 3 m intake + 3 m exhaust, etc.), to ensure correct operation.

It should be remembered that a bend is equivalent to a straight segment of about 50 cm. If the exhaust duct layout is exposed to low temperatures, prevent condensation from forming by using suitable insulation on that duct.

#### 4.3 OUTSIDE POSITIONING OF THE FLUE GAS EXHAUST TERMINAL

The position of the flue gas exhaust terminal and its distance from windows, ventilation openings, etc. must comply with what is prescribed by the current standards.

If the air heater is installed in rooms on the ground floor and the exhaust faces sidewalks at the level of pedestrians, a special protection grille must be applied, which is supplied on request (fig. 14).

#### 4.4 INSTALLATION OPERATIONS

Set up the gas and electricity supply lines based on the installation design.

##### 4.4.1 Air heater wall-mounting preparations (appliance with standard supply - Installation Type C<sub>12</sub>)

Once the position and the height of the appliance from the ground has been determined, use the

wall template from the cardboard packing to indicate the positions of the holes to be made (three holes to attach the appliance with an Ø 8 mm bit for expansion bolts, one hole for the intake/exhaust duct with special hole cutter Ø 70 mm, to be made as perpendicular as possible to the direction of the wall).

The template also indicates the positions of the electric power supply cable and gas feeder pipe entries.

##### 4.4.2 Mounting the intake/exhaust duct (appliance with standard supply - Installation Type C<sub>12</sub>)

The intake/exhaust duct, supplied for walls up to 40 cm, consists of an aluminium pipe with connector flange and an external terminal. Mount the duct in the sequence described below:

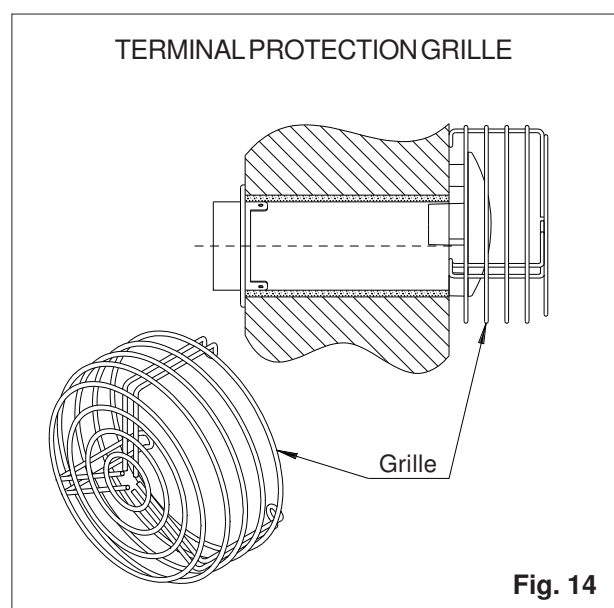



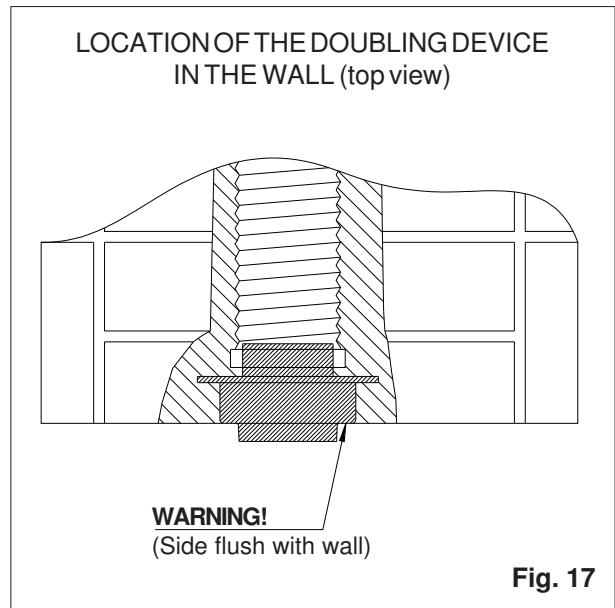
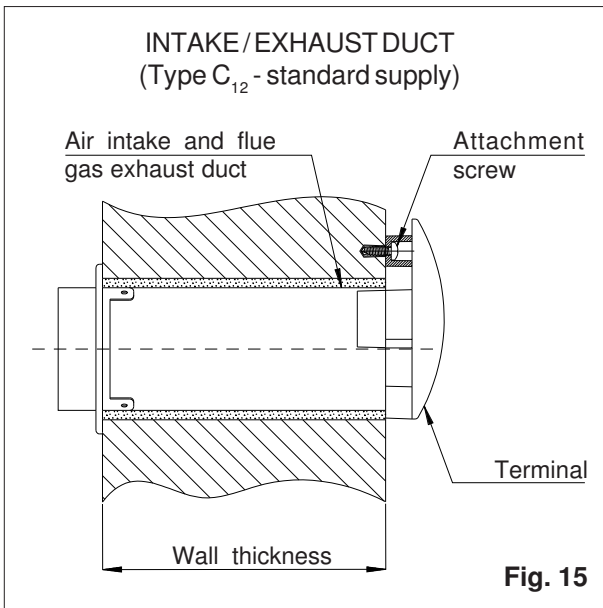

- a) precisely measure the thickness of the wall. This measurement corresponds to the distance between the flange and the point in which the duct must be cut (fig. 15)
- b) use a hack saw to cut the aluminium duct to the specific measurement. Trim off any burrs using a file
- c) insert the duct into the appliance using the special gasket and tighten it with the three screws supplied with the kit.

**WARNING! The duct can only be connected in one direction; do not force the pipe if resistance is felt. Note the position of the pipe on the flange and turn it in the correct position, if necessary.**

#### 4.4.3 Air heater wall-mounting preparations and duct installation (appliance with accessories for separate intake and exhaust ducts - Installation Type C<sub>52</sub>)

Unlike the previous solution, to mount the duct doubling device a recessed housing must be created in the wall and possibly some chases to indicate the duct layout (fig. 16).

Therefore, by positioning the cardboard template, the centre of the appliance intake/exhaust fitting must be traced on the wall. The centre of the similar doubling device fitting must be in the same position.

Create the depression in the wall for the doubling device and make the necessary chases to house the ducts, whether or not they are the rigid or the

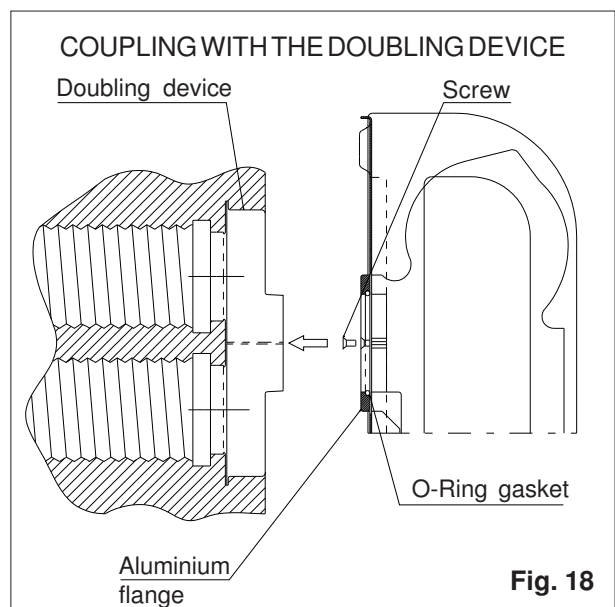
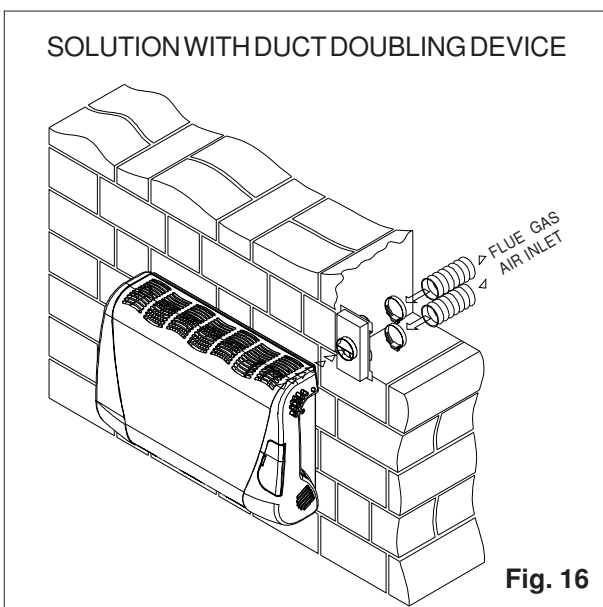

bendable type in stainless steel. Connect the ducts to the doubling device using metal clamps and tighten them to ensure a good seal on the fitting. With the doubling device connected in this manner, place it in the housing and block it into position using cement mortar.

**Make sure to respect the position indicated in fig. 17, so that only the circular fitting projects from the finished wall, while the interior of the doubling device is flush with that wall.**

**WARNING! The seal of the connector between the doubling device and the appliance is created by a special gasket (fig. 18). Make sure that the wall on which the air heater is installed is perfectly flat, so that the subsequent attachment of the appliance does not change the coupling.**

Assemble the ducts in the chases up to the relative external terminal, carefully checking any joints (if a rigid tube is used make sure that the special unions and gaskets are mounted correctly).

**WARNING! It is recommended to insulate the duct by using insulating material that is suitable for the temperatures generated (for example, glass fibre mattress for temperatures up to 200°C), to prevent condensation from forming inside the duct and/or to avoid cracks in the plaster due to the high temperature. At the end of the previous operations close the chases, making sure that the cement mortar completely covers the ducts and that there are no empty spaces.**

Place the previously used template on the wall, centering the position of the intake/exhaust fitting onto the corresponding centre of the walled doubling device, and mark the position of the three holes to attach the appliance. The holes should be drilled using an Ø 8 mm bit for expansion bolts.

To adapt the intake/exhaust fitting of the appliance to the coupling with the doubling device connector, do the following operations:

- a) remove the three screws inserted in the fitting on the appliance (they will not be used again)
- b) mount the aluminium flange Ø 92 mm, inserting the ring gasket and attaching it on the appliance fitting using the three screws supplied with the kit. Check that the ring gasket fits correctly into its housing (fig. 18).

#### 4.4.4 Appliance wall mounting

##### a) Appliance with standard supply - Installation Type C<sub>12</sub>

Lift the appliance and, putting the intake/exhaust duct at the beginning of the hole, push it toward the wall until contact is made.

Adjust the position of the appliance and attach it with the expansion screws that were previously inserted into the wall. On the exterior, check that the intake/exhaust duct ends flush with the wall.

Insert the external wind protection terminal on the duct and mark the position of the hole for the expansion bolt to be drilled in the wall (fig. 15). After drilling the hole, re-insert the terminal and attach it permanently, checking its stability.

##### b) Appliance with accessories for separate intake and exhaust ducts - Installation Type C<sub>52</sub>

Lift the air heater and slowly bring it closer to the wall until coupling the two intake/exhaust connectors located on the doubling device and on the appliance.

Making sure not to change the coupling described above, adjust the position of the appliance and attach it using the expansion screws that were previously inserted into the wall.

**In both cases described above, it is recommended to use two persons to lift and position the air heater to avoid any possible damage to the wall or the appliance.**

#### 4.4.5 Gas connection

Mount the gas on-off valve supplied with the appliance using the special gasket. Connect the gas supply line to the valve which is equipped with a female threaded attachment G 3/8".

**WARNING!: The valve must be located in a position that can be easily accessed by the user.**

Check the seal on the gas piping and make sure that it was created in conformity with the current standards regarding gas installations.

#### 4.4.6 Electrical connections

Ensure that a single-phase, 230 V ~ 50 Hz electric power supply is available.

**The appliance must be properly insulated by means of an omnipolar circuit-breaker with**

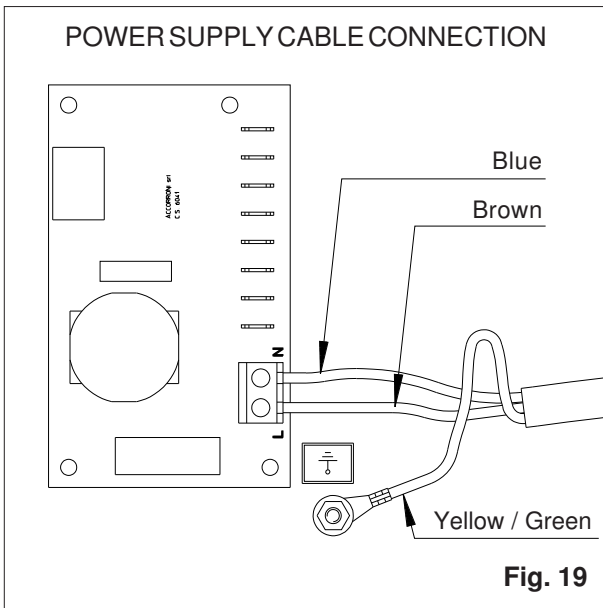

**an adequate rating to be used as a general switch to turn off the appliance(s).**

Connect the power supply cable to the phase, neutral terminals and to the earth connection of the appliance. Insert the power supply cable through the special cable gland, making sure to cut the wires so that the yellow/green earth cable is slightly longer than the other two.

This precaution, in case of accidental detachment, allows the earth cable to be the last connection to be removed (*fig. 19*).

**Comply with the phase/neutral polarity, otherwise the control equipment will generate a safety lock out.**

**THESE APPLIANCES MUST BE EARTHED.**

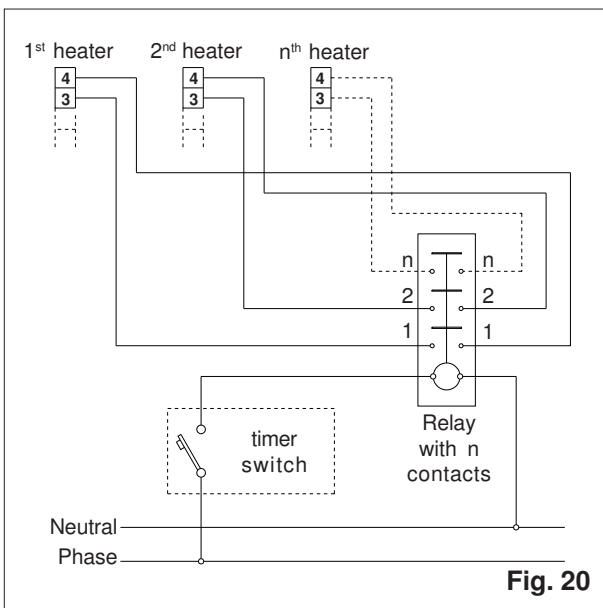

#### 4.4.7 Using a timer (the kit is supplied on request)

To operate the air heater automatically at predetermined hours, it is possible to install a digital timer on the appliance, even after the appliance has already been installed. The timer is supplied on request as an assembly kit.

#### 4.4.8 Connecting more than one unit with a single external timer

To operate several appliances with just one timer follow the diagram given in *fig. 20* to avoid malfunctions of the entire installation.

To complete this special connection, use a normally open contact relay with an adequate rating. Terminals 3 and 4 will be connected to the terminal board of the appliances, after having removed the existing bridge.

### 5. START-UP

**WARNING! The appliance initial start-up operations and tests must be performed by skilled technical personnel.**

#### 5.1 TESTS

**5.1.1** Before starting the air heater, make sure that all the current provisions and standards relevant to the installation of these appliances have been observed. Pay particular attention to the correct positioning of the combustion product exhaust terminal.

**5.1.2** Make sure that the single-phase, 230 V ~ 50 Hz electric power supply and the earth wire are connected to the special air heater terminals. The phase conductor must be connected to the terminal marked with the letter "L", otherwise the control equipment will generate a safety lockout.

**5.1.3** Check that the gas injector mounted on the burner corresponds to what is indicated for the type of gas to be used (*table on page 11*).

**WARNING! The appliance are delivered already set in the factory to use natural gas G20, with a supply pressure of 20 mbar. Instead, if gas from the third group is used (G30 - G31), first carry out the operations described in point 6.1.**

**5.1.4** Check that the gas on-off valves on the meter and on the air heater are open. Make sure that the air inside the gas supply piping has been purged.

## 5.2 IGNITION

### 5.2.1 Ignition procedure

(Refer to fig. 21 when reading the following section )

- Place switch (A) in the on position "I" to start the ignition cycle. If the digital timer has been installed, refer to the instructions for that device to perform the additional operations.
- Turn the room thermostat dial (D) clockwise to the highest value. This marks the beginning of the start-up phase, indicated when the green led (E) turns on.
- Check that the red led (F) is turned off. If it is on, this means that the burner control equipment is in the "lockout" position. In this case, press the button (C) to reset the control equipment, and the red light will turn off.

After completing the pre-purge phase (after about 30 seconds), the system simultaneously opens the gas solenoid valve and activates the transformer to discharge the electrode to ignite the burner.

From the moment in which the burner is ignited, the flame must be detected by the special ionisation sensor within the specific safety time, otherwise the control equipment enters the lock out mode, indicated when the red led (F).

This may occur in particular in a new plant due to air in the gas piping. In this case, wait about one minute and reset the appliance by pressing the "reset" button (C) to begin a new cycle.

Repeat the operation until the residual air has

been purged and the ignition is regular.

The exchanger heating phase begins after the burner has been ignited. The exchanger reaches the rated operating temperature after about three minutes and at that point a thermostat starts the fan to distribute warm air in the environment.

### 5.2.2 Controls

**WARNING! When operations or visual inspections are performed on the air heater, be extremely cautious and work under safe conditions.**

Insert the water column pressure gauge tube into the pressure outlet on the gas unit (fig. 22) after having backed off the screw a few turns. Start the air heater and check that the pressure to the burner corresponds to what is indicated in the technical data table.

If the pressure of the gas delivered to the burner does not correspond to the value indicated, use the special pressure set screw (fig. 22), after having removed the protection plug, to obtain the specified value. Turn it counterclockwise to decrease the pressure and clockwise to increase the pressure (this operation can be carried out only when using natural gas G20).

Turn the room thermostat dial to the minimum value and check that the burner shuts off.

Remove the pressure gauge tube and tighten the pressure regulator screw, carefully checking the seal. Replace the regulator protection plug.

**WARNING! When the burner turns off, the fan(s) will continue to operate for a few minutes, to properly cool the exchanger. Therefore, it is important not to turn off the air heater using the mains switch, that also cuts off the power supply to the fan(s), since this might lead to overheating and trip the safety thermostat.**

Then repeat the start-up operation to observe and check that the burner has ignited correctly and that the flame is stable.

## 5.3 USEFUL INFORMATION

**It is recommended that the user be informed about all the operations necessary to use the air heater correctly, with particular reference to the ignition and shutdown phases and about the importance of periodic tests, which must be performed at least once every year by skilled personnel.**

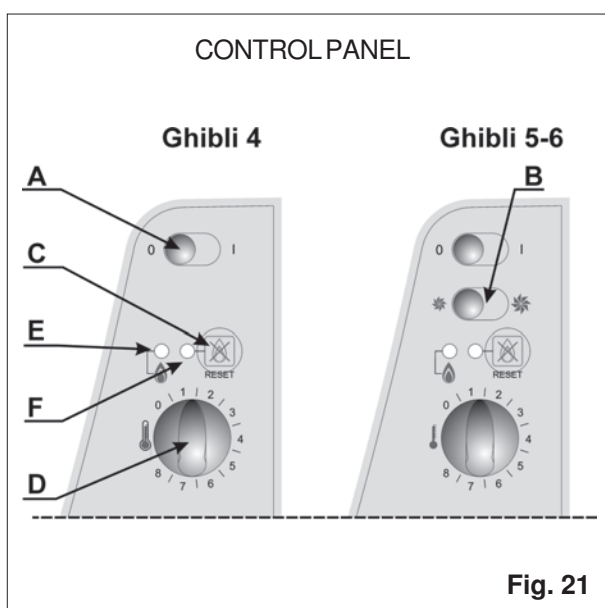

## 6. GAS TYPE CHANGE

**WARNING!** The operations described below must be carried out by skilled technical personnel.

### 6.1 SWITCHING FROM GAS IN THE SECOND GROUP (G20) TO GAS IN THE THIRD GROUP (G30 - G31)

- a) Check that the envelope supplied with the air heater contains the replacement injector, the screw block with pin and the adhesive label, on which to indicate the new type of gas being used, to replace the original one
- b) check that the diameter of the injector indicated for the type of gas to be used (see *technical data table on page 11*) corresponds to what is stamped on the injector.
- c) close the gas on-off valve and disconnect the electric power supply. Remove the air heater casing using the two screws located at the bottom and the two screws at the top, which can be accessed by using the screwdriver supplied with the kit
- d) remove the 6 screws which attach the burner support plate to the combustion chamber. Pull it out making sure not to damage the seal gasket. Disassemble the gas injector using a 10 mm hex wrench and replace it with the new one, then re-tighten it to ensure a proper seal (*fig. 23*)
- e) replace the burner support plate making sure that the gasket is in the correct position. Attach the plate using the 6 screws that were previously removed

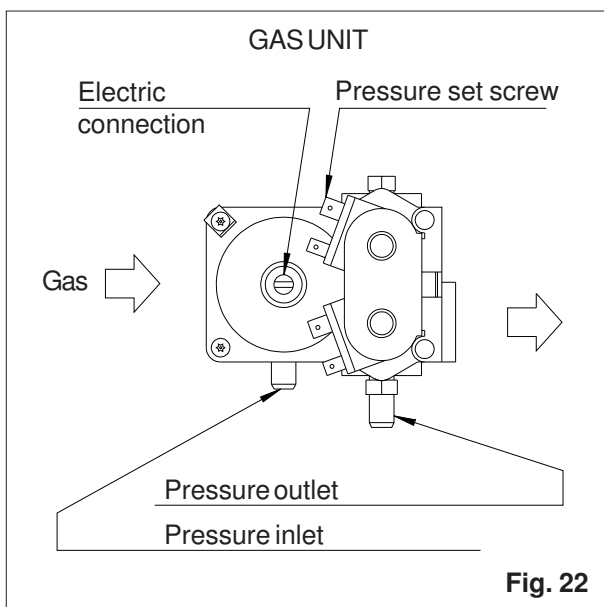
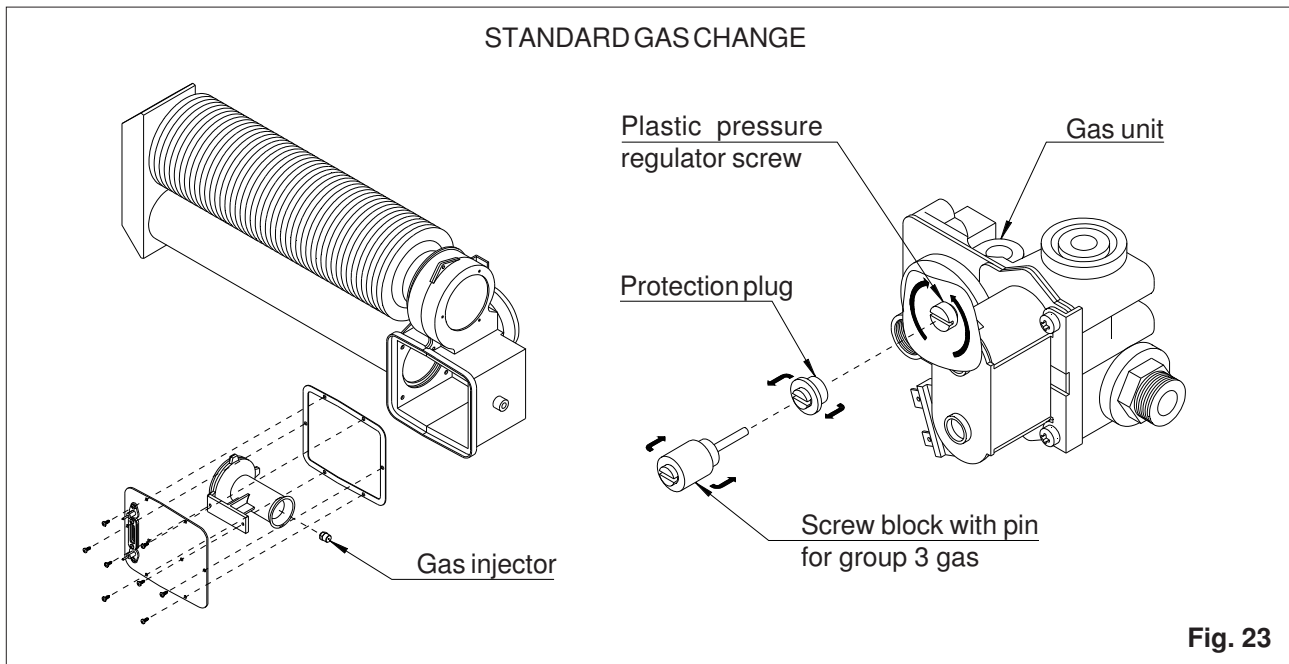

Fig. 22

- f) unscrew the pressure regulator protection plug located on the gas unit. With care, fully tighten the plastic screw of the pressure regulator. Insert the screw block with pin instead of the protection plug to put the regulator out of service (*fig. 23*). **Keep the pressure regulator protection plug for future use**
  - g) insert the water column pressure gauge tube into the upstream pressure inlet on the burner (*fig. 22*) after having backed off the closing screw a few turns
  - h) start the air heater according to what is indicated in *point 5.2*. Check that the supply pressure corresponds to what is indicated in the technical data table. If the gas supply pressure does not correspond to the value indicated, use the pressure regulator (second stage) installed externally to obtain the correct value
  - i) remove the pressure gauge tube and tighten the pressure inlet screw
  - l) use a special spray or electronic leak detector to identify any leaks in the gas circuit
  - m) replace the air heater casing and attach it at the four special points.
- ### 6.2 SWITCHING FROM GAS IN THE THIRD GROUP (G30 - G31) TO GAS IN THE SECOND GROUP (G20)
- a) check that the adaptation kit envelope contains the replacement injector and the adhesive label, on which to indicate the new type of gas being used, to replace the original one
  - b) close the gas on-off valve and disconnect the electric power supply. Remove the air heater casing using the two screws located at the bottom and the two screws at the top, which can be accessed by using the screwdriver supplied with the kit
  - c) remove the 6 screws which attach the burner support plate to the combustion chamber. Pull it out making sure not to damage the seal gasket. Disassemble the gas injector using a 10 mm hex wrench and replace it with the new one, then re-tighten it to ensure a proper seal (*fig. 23*)
  - d) replace the burner support plate making sure that the gasket is in the correct position. Attach the plate using the 6 screws that were previously removed
  - e) on the gas unit, remove the screw block with pin located on the pressure regulator to reset regulation operation (*fig. 23*)



- f) start the air heater according to what is indicated in *point 5.2*
- g) insert the water column pressure gauge tube into the pressure outlet on the gas unit burner (*fig. 22*) after having backed off the closing screw a few turns. Check that the supply pressure corresponds to what is indicated in the technical data table. If the gas supply pressure to the burner does not correspond to the value indicated, use the pressure regulator (*fig. 22*) to obtain the correct value. Turn counterclockwise to decrease the pressure and clockwise to increase the pressure
- h) remove the pressure gauge tube and tighten the pressure inlet screw. Insert the regulator protection plug (original equipment)
- l) use a special spray or electronic leak detector to identify any leaks in the gas circuit

## **7. OPERATING DEFECTS**

### **7.1 PRELIMINARY TESTS**

Before performing specific tests, make sure that:

- a) the electric power supply is properly connected (with particular attention focused on the phase-neutral polarity and earth connector)
- b) the gas supply is correct, the gas on-off valve is open and the pressure to the burner corresponds to what is indicated in the technical data table
- c) the external terminal of the combustion air intake and combustion product exhaust duct is not obstructed

### **7.2 POSSIBLE DEFECTS**

The following is a list of possible defects along with their probable causes. *The information indicated in italics refers to repair operations or corrections which are the responsibility of the authorised Technical Service Centre.*

#### **7.2.1 The appliance does not start even if the conditions described in the previous points are correct.**

- a) the flame detection circuit of the control equipment is malfunctioning and the initial self-check does not allow the cycle to continue.
  - *Replace the control equipment (see point 8.1).*
- b) The flame detection electrode has an earth leakage.
  - *Check the correct position of the electrode. The ceramic insulation material may be cracked and this is difficult to determine visually. In case of doubt, replace the electrode (see point 8.6).*

#### **7.2.2 At the end of the pre-ventilation phase, the ignition electrode does not discharge and the control equipment locks out within the safety time.**

- a) The ignition transformer is malfunctioning.
  - *Replace the control equipment which contains the transformer.*
- b) The ignition electrode is no longer connected to the equipment connector.

- *Restore the connection or replace the electrode including the cable. Do not make joints to avoid reducing the cable insulation level.*
- c) The ignition electrode is not correctly positioned or its ceramic insulation is damaged, with a subsequent leakage of the ignition discharge.
  - *Replace the electrode including the cable.*

**7.2.3 At the end of the pre-ventilation phase, the ignition electrode discharges, but the flame is not formed and the control equipment locks out within the safety time.**

- a) No gas supply or there is air inside the piping.
  - *Determine why there is no gas supply first checking the on-off components on the feed line. Completely bleed off any residual air and restart the appliance.*
- b) The gas solenoid valves do not open because the coils are malfunctioning or their electrical connection has been interrupted.
  - *Check if the connection cable and relative terminals have been damaged. Use a special tool to verify that the coils have failed and replace them, if necessary (see point 8.3).*
- c) The safety thermostat is malfunctioning and does not allow the solenoid valves to open.
  - *Replace the safety thermostat (see point 8.5).*

**7.2.4 At the end of the pre-ventilation phase, the ignition electrode discharges, the flame is formed correctly, but the control equipment locks out within the safety time.**

- a) The phase-neutral electric power supply is not correctly connected to the respective terminals, marked as "L" and "N" and reversing the polarity may de-activate the flame detection device.
  - *Check using a multimeter or phase detector and correctly connect the cables to the corresponding terminals.*
- b) The flame detection electrode is not correctly positioned and is not in contact with the flame.
  - *Check if the electrode is properly connected and if there are any deformations. Comply with what is indicated in figure 28.*
- c) The flame detection electrode electric connection has been interrupted.
  - *Check the electrode connection to the control equipment. If the cable or ceramic insulation is damaged, replace the electrode in*

*accordance with the positions indicated in figure 28.*

- d) The flue gas exhaust fan motor is malfunctioning or does not operate correctly because the intake/exhaust duct is obstructed.
  - *First eliminate any obstructions in the terminal and, if necessary, replace the fan, making sure to re-assemble the unit as shown in fig. 29 (see point 8.8)*

**7.2.5 The control equipment locks out during normal operation**

- a) The gas supply was cut off and the equipment, after repeating the ignition cycle, and without detecting the flame within the safety time period, entered the lock out mode.
  - *Determine why the gas supply prior to the air heater was interrupted. Restart the appliance using the Reset button on the control panel.*
- b) The incorrect positioning of the external intake and exhaust terminal has caused combustion products to return and this prevents the flame from being formed and therefore from being detected by the electrode.
  - *Check that the terminal is not installed inside niches or recesses in the walls and that there are no obstructions that prevent the air from circulating.*
- c) The safety thermostat cuts off the supply to the gas solenoid valve because overheating has occurred due to incorrect operation or a failure of the convection fan.
  - *Check for obstructions or dust deposits on the fan and/or relative grille. Replace the malfunctioning fan, if necessary (see point 8.8).*
- d) The safety thermostat cuts off the supply to the gas solenoid valve because overheating has occurred due to incorrect operation of the fan control thermostat.
  - *Replace the fan control thermostat (see point 8.4).*

**7.2.6 The burner stops while it is operating, even if the room temperature does not require it**

- a) The room thermostat is defective.
  - *First check that the thermostat sensor is in the correct position and that its operation has not been affected by dust deposits. Otherwise, replace the defective room thermostat.*

## 8. REPLACING PARTS

Since specific technical skills are required to replace the parts listed below, it is recommended to advise the user to always contact skilled technical personnel. For safety and quality reasons, it is recommended to use original spare parts when replacing components.

**WARNING!** All the following operations must be carried out while the heater is turned off, disconnecting the gas and electric supplies.

### 8.1 CONTROL EQUIPMENT

Disconnect the cables by pulling on the terminals and extracting the connectors, releasing them first from the special retainer. Replace the equipment, placing it in the special insert and attaching it using the self-threading screw. Insert the terminals and the connectors into their respective housings (fig. 24).

### 8.2 FUSE

Using a special tool, remove the fuse holder on the power supply terminal board. Replace it with a new fuse (5x20 -2 Amps - instantaneous type) by exerting slight pressure until it enters the housing. Replace the fuse cap in the terminal board.

### 8.3 GAS SOLENOID VALVES

Disconnect the electric connection on the gas unit. Remove the two screws that attach the metal support block of the coils and remove it from the housing. Pull out the coil(s) from the unit and replace them with new ones. Replace the metal support block in the correct position and tighten the fastening screws. Re-establish the electrical connection (fig. 25).

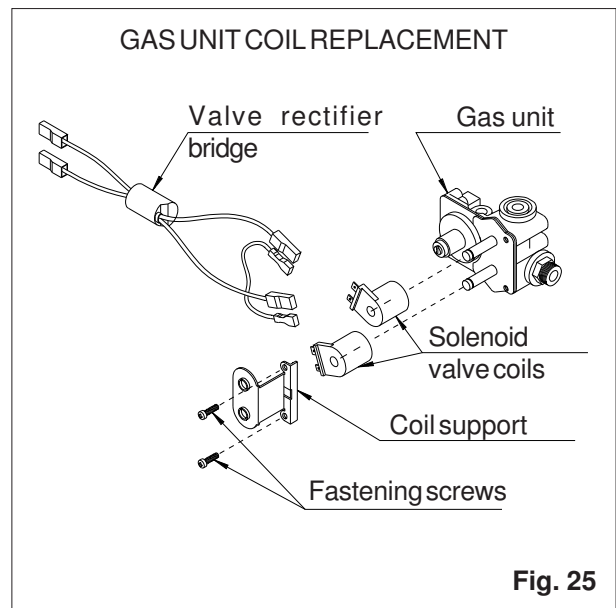
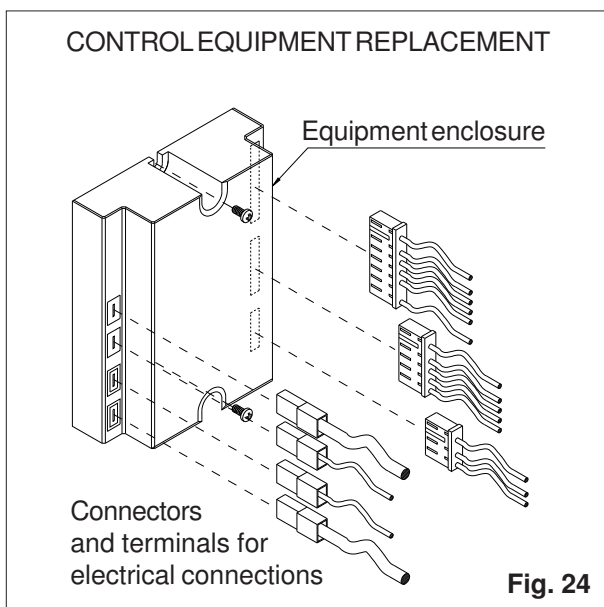

### 8.4 CONVECTION FAN CONTROL THERMOSTAT

Disconnect the cables and unscrew the thermostat from the threaded support. Insert the new thermostat, screwing it all the way in by hand (do not use tools which might damage the thermostat). Make sure that the distance between the thermostat enclosure and the threaded support is not greater than 3 mm, to guarantee that the sensor remains in contact with the wall of the exchanger. Re-establish the electrical connection (fig. 26).

### 8.5 SAFETY LIMIT THERMOSTAT

Disconnect the electric connection of the thermostat on the appliance terminal board. Release the thermostat by disassembling the attachment plate on the air heater shield. Mount the new thermostat by reversing the order of the

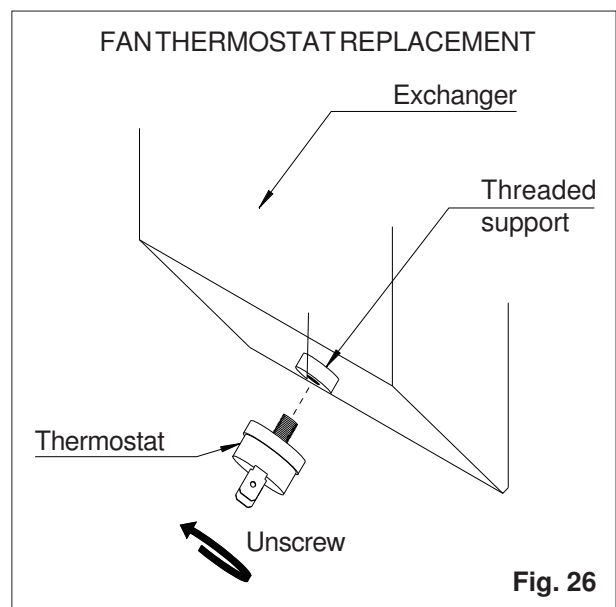



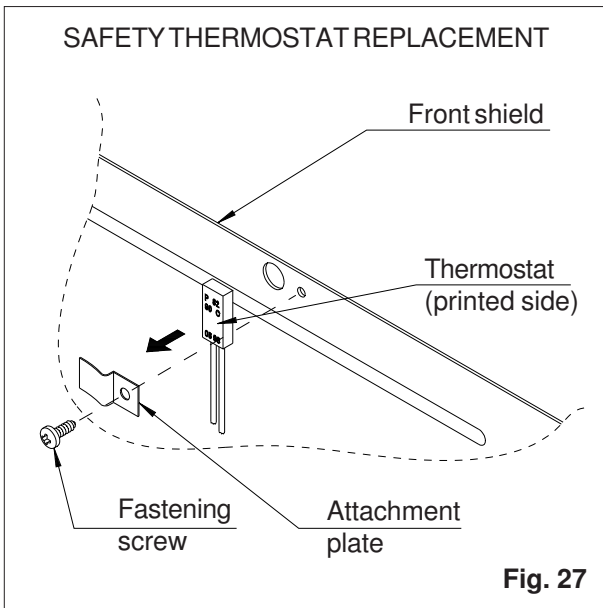

previous operations. Make sure to insert the side of the thermostat with the printed data facing the air heater shield (*fig. 27*).

### 8.6 ELECTRODES

Disconnect the cable connection on the control equipment. Remove the fastening screws and pull out the electrodes from the burner plate. Insert the new electrodes, attach the supports and re-establish the electrical connection. To check the position of the electrodes on the burner, remove the burner support plate from the combustion chamber and extract it, making sure not to damage the seal gasket.

The position of the electrodes with respect to the burner must correspond to what is indicated in *fig. 28*. Replace the burner support plate while checking that the relative gasket is in the correct

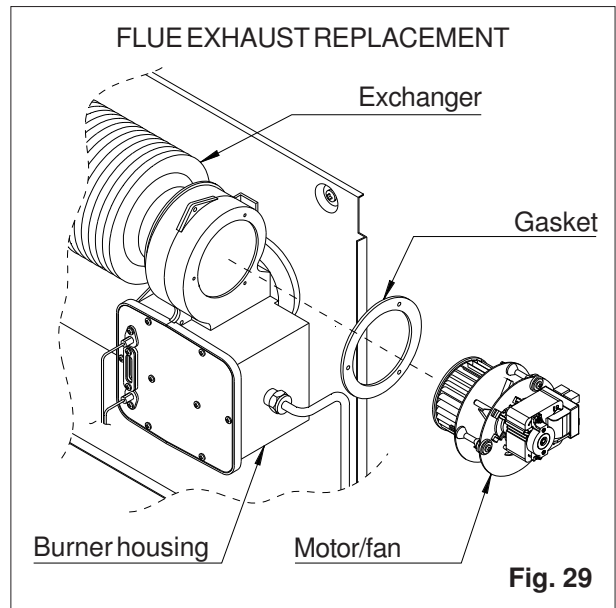
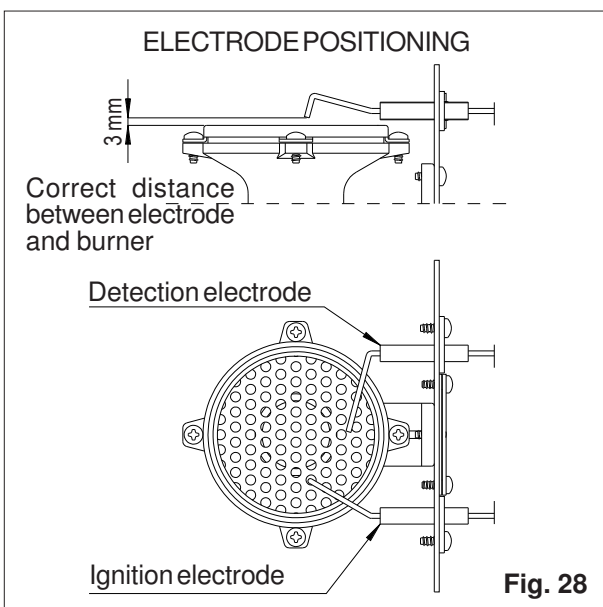

position. Attach the plate using the 6 screws that were previously removed.

### 8.7 FLUE EXHAUST FAN

Disconnect the motor electrical connection and loosen the three scroll fastening screws. Gently remove the motor-fan unit and, respecting the original position, insert the new unit. Tighten the screws and re-establish the electrical connection. Make sure the fan rotates correctly and without friction (*fig. 29*).

### 8.8 CONVECTION FAN

#### 8.8.1 Ghibli model 4

Disconnect the power supply from the fan motor electrical connections. Unscrew the four screws that attach the support brackets of the fan to the rear panel of the air heater. Insert the new fan,

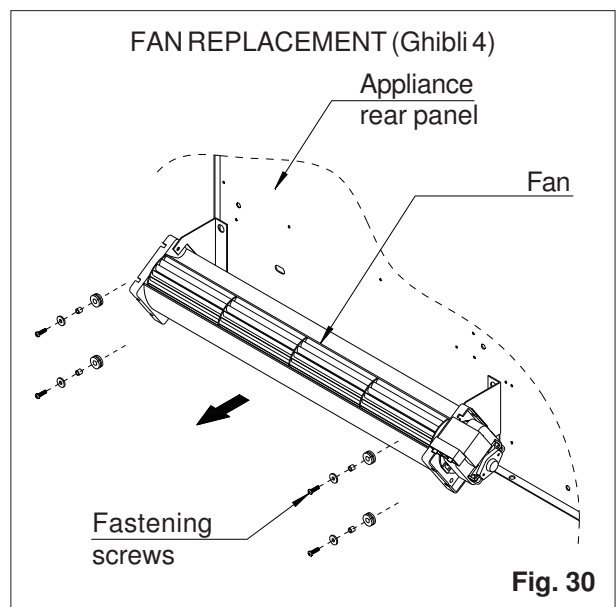

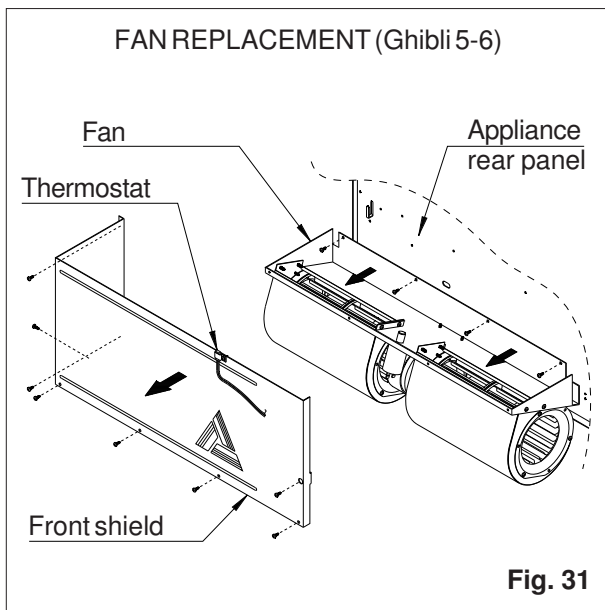

including brackets, into position, making sure that the grommets with relative spacers are in the correct position (*fig. 30*). Attach the fan brackets using the screws that were previously removed and re-establish the electrical connection. Remove any dust deposits on the casing air grille.

### 8.8.2 Ghibli models 5 and 6

Disconnect the fan power supply from the air heater terminal board and from the speed switch on the control panel. Disassemble the front shield of the appliance (8 fastening screws) to access the four screws that are used to attach the fan (*fig. 31*). Carefully remove the fan and replace it with a new one, reversing the operations described above. Check the cable connections by referring to the circuit diagram. Remove any dust deposits on the casing air grille.

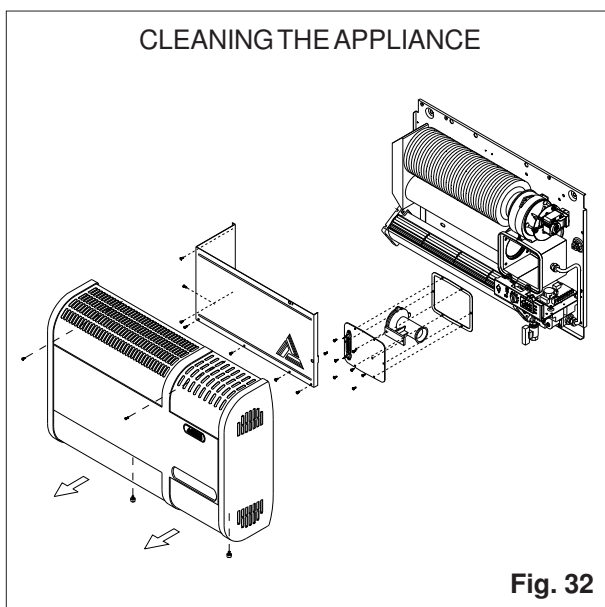

## **9. PERIODIC MAINTENANCE OPERATIONS**

### **9.1 USER INFORMATION**

It is recommended to advise the user to carry out the operations indicated in point 11.1 of this manual at least once every two months.

### **9.2 YEARLY INSPECTION**

#### **9.2.1 Control and safety devices**

**WARNING! Specific technical skills are required to test the control and safety devices and this is why it is important to contact skilled personnel.**

#### **9.2.2 Cleaning the appliance**

Remove the air heater casing using the two screws located at the bottom and the two screws at the top, which can be accessed by using the screwdriver supplied with the kit. Remove any dust deposits on the air uptake and delivery grilles on the casing.

Disassemble the front shield of the appliance and clean the exchanger and the fan, using a brush or a jet of compressed air.

Remove any dust deposits from the safety and fan thermostats and from the room thermostat sensor.

Remove the 6 screws which attach the burner support plate to the combustion chamber. Pull it out making sure not to damage the seal gasket. Check the condition of the burner and its parts. Check that there are no carbon deposits inside the exchanger pipe. If deposits are found, look for the causes of a what is likely a non-efficient combustion.

Replace the burner support plate making sure that the relative gasket is in the correct position. Attach the plate using the 6 screws that were previously removed.

Check that the external intake/exhaust terminal is in the correct position and that it is clean.

Check the condition of the electric system and check the efficiency of the connections.

Carefully replace the components and check that they operate regularly (*fig. 32*). Carefully carry out all the operations described from point 5.1 to point 5.2.2 and, if problems arise, consult chapter 7 about operating defects.

# SECTION 3

## USER OPERATING AND MAINTENANCE INSTRUCTIONS

### 10. START-UP

#### 10.1 FIRST FIRING AND TESTING

**WARNING! The first firing of the appliance and the commissioning tests must be performed by skilled technical personnel. Non-compliance with this procedure will invalidate the warranty conditions and release the manufacturer from all responsibilities.**

#### 10.2 TESTS

Before operating the heater, make sure that the installer has correctly carried out the installation operations.

#### 10.3 IGNITION

**WARNING! Any operation on the appliance not expressly described below must be performed by skilled personnel.**

**10.3.1** Check that the gas on-off valves are open and the electric power supply is on.

**10.3.2** (The instructions to the control panel functions which follow refer to fig. 33).

- Place switch (A) in the on position "I" to start the ignition cycle. If the digital timer has been installed, refer to the instructions for that device to perform the additional operations.
- Turn the room thermostat dial (D) clockwise to the highest value. This marks the beginning

of the start-up phase, indicated when the green led (E) turns on.

- Check that the red led (F) is turned off. If it is on, this means that the burner control equipment is in the "lockout" position. In this case, press the button (C) to reset the control equipment, and the red led will turn off. **If the lockout condition continues, this generally means that there is a fault or an operating defect. Therefore, it is recommended to contact a Technical Service Centre.**

The exchanger heating phase begins after the burner has been ignited. The exchanger reaches the rated operating temperature after about three minutes and at that point a thermostat starts the fan to distribute warm air in the environment. Models 5 and 6 offer two different fan speeds which are selected by using a switch (B).

When the room has reached the desired temperature, adjust the room thermostat by turning the control dial slowly (counterclockwise) until the burner turns off (indicated by the green led E). From this point on the air heater will be completely automatic and will maintain the desired room temperature.

#### 10.4 SHUTDOWN

**10.4.1** To turn off the air heater for a short period of time, just use the room thermostat, just set the switch (A) to the "OFF" position, without moving the temperature regulation dial.

**WARNING!** When the burner turns off, the fan will continue to operate for a few minutes, to properly cool the exchanger. Therefore, it is important not to turn off the air heater using the main switch, that also cuts off the power supply to the fan, since this might lead to overheating.

**10.4.2** To turn off the air heater for an extended period of time:

- set the switch (A) to the "OFF" position
- after the fan has turned off, disconnect the electric power supply at the main switch
- close the gas on-off valve

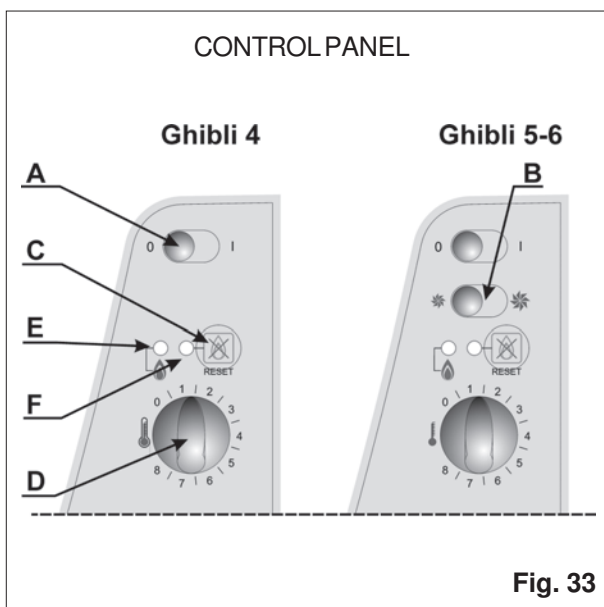

Fig. 33

## **11. APPLIANCE MAINTENANCE**

### **11.1 ROUTINE MAINTENANCE TO BE PERFORMED BY THE USER**

It is recommended that the following operations be carried out at the beginning of each heating season and then at least once every month during operation:

**WARNING! The operations described in points a) and b) must be performed while the air heater is not functioning, and with the gas and electric supplies turned off.**

a) check that the external terminal of the intake/exhaust duct is not obstructed or that the relative material has deteriorated

b) clean the external parts of the air heater simply by using a damp cloth and use a brush to remove any dust deposits on the air intake grille

c) make sure that the operation of the appliance is normal, as described in *point 10.3*.

### **11.2 ANNUAL AIR HEATER INSPECTION**

To reduce possible failures to a minimum and to keep the air heater operating at peak efficiency, it is recommended that a general inspection of the air heater be carried out at least once a year by skilled personnel.

# ACCORRONI - GHIBLI 4 ELITE



**ENERG**  
енергия · ενεργεια





**GHIBLI 4 ELITE**



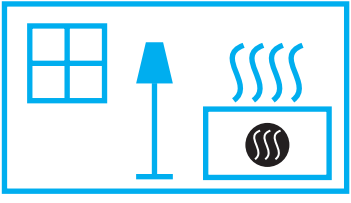

## 3,35

kW

ENERGIA - ЕНЕРГИЯ - ΕΝΕΡΓΕΙΑ - ENERGUA - ENERGY - ENERGIE - ENERGI

2016/2281

Model identifier	GHIBLI 4 ELITE
Indirect heating functionality	no
Direct heat output (kW)	3,35
Indirect heat output (kW)	no

Fuel type	Space heating emissions (*)	
	NOx	
G20/G25/G30/G31	Gaseous	69 mg/kWh (GCV)

(\*) NOx = nitrogen oxides

#### Permanent pilot flame power requirement

	Symbol	Value	Unit
Pilot flame power requirement	P <sub>pilot</sub>	no	kW

Contact details	A2B ACCORRONI E.G. S.r.l. via d'Ancona, 37 60027 Osimo (AN) Italia
-----------------	--

#### Heat output

	Symbol	Value	Unit
Nominal heat output	P <sub>nom</sub>	3,35	kW
Minimum heat output	P <sub>min</sub>	3,35	kW

#### Auxiliary electricity consumption

	Symbol	Value	Unit
At nominal heat output	el <sub>max</sub>	0,047	kW
At minimum heat output	el <sub>min</sub>	0,047	kW
In standby mode	el <sub>SB</sub>	0,005	kW

#### Positive influence on $\eta_{s, on}$

	Symbol	Value	Unit
Positive influence	$\eta_{s, on}$	7	%

#### Energy efficiency class

	Symbol	Value	Unit
Energy efficiency class	$\eta_s$	83,1	%

# ACCORRONI - GHIBLI 5 ELITE



**ENERG**  
енергия · ενέργεια





**GHIBLI 5 ELITE**



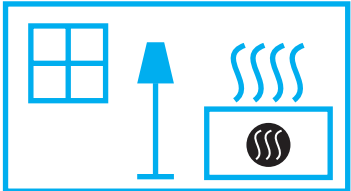

## 4,37

kW

ENERGIA - ЕНЕРГИЯ - ΕΝΕΡΓΕΙΑ - ENERGUA - ENERGY - ENERGIE - ENERGI

2016/2281

Model identifier	GHIBLI 5 ELITE
Indirect heating functionality	no
Direct heat output (kW)	4,37
Indirect heat output (kW)	no

Fuel type	Space heating emissions (*)	
	NOx	
G20/G25/G30/G31	Gaseous	68 mg/kWh (GCV)

(\*) NOx = nitrogen oxides

#### Permanent pilot flame power requirement

	Symbol	Value	Unit
Pilot flame power requirement	P <sub>pilot</sub>	no	kW

Contact details	A2B ACCORRONI E.G. S.r.l. via d'Ancona, 37 60027 Osimo (AN) Italia
-----------------	--

#### Heat output

	Symbol	Value	Unit
Nominal heat output	P <sub>nom</sub>	4,37	kW
Minimum heat output	P <sub>min</sub>	4,37	kW

#### Auxiliary electricity consumption

	Symbol	Value	Unit
At nominal heat output	el <sub>max</sub>	0,080	kW
At minimum heat output	el <sub>min</sub>	0,080	kW
In standby mode	el <sub>SB</sub>	0,005	kW

#### Positive influence on $\eta_{s, on}$

	Symbol	Value	Unit
Positive influence	$\eta_{s, on}$	7	%

#### Energy efficiency class

	Symbol	Value	Unit
Energy efficiency class	$\eta_s$	82,7	%

# ACCORRONI - GHIBLI 6 ELITE



**ENERG**  
енергия · ενεργεια





## GHIBLI 6 ELITE



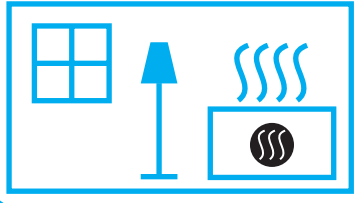

4,91

kW

ENERGIA - ЕНЕРГИЯ - ΕΝΕΡΓΕΙΑ - ENERGUA - ENERGY - ENERGIE - ENERGI

**2016/2281**

Model identifier	GHIBLI 6 ELITE
Indirect heating functionality	no
Direct heat output (kW)	4,91
Indirect heat output (kW)	no

Fuel type	Space heating emissions (*)	
	NOx	
G20/G25/G30/G31	Gaseous	50 mg/kWh (GCV)

(\*) NOx = nitrogen oxides

#### Permanent pilot flame power requirement

	Symbol	Value	Unit
Pilot flame power requirement	P <sub>pilot</sub>	no	kW

Contact details	A2B ACCORRONI E.G. S.r.l. via d'Ancona, 37 60027 Osimo (AN) Italia
-----------------	--

#### Heat output

	Symbol	Value	Unit
Nominal heat output	P <sub>nom</sub>	4,91	kW
Minimum heat output	P <sub>min</sub>	4,91	kW

#### Auxiliary electricity consumption

	Symbol	Value	Unit
At nominal heat output	el <sub>max</sub>	0,102	kW
At minimum heat output	el <sub>min</sub>	0,102	kW
In standby mode	el <sub>SB</sub>	0,005	kW

#### Positive influence on $\eta_{s, on}$

	Symbol	Value	Unit
Positive influence	$\eta_{s, on}$	7	%

#### Energy efficiency class

	Symbol	Value	Unit
Energy efficiency class	$\eta_s$	80,5	%



A2B ACCORRONI E.G. S.r.l. - Via d'Ancona, 37 - 60027 Osimo (An)  
Tel. 071.723991 - Fax 071.7133153 - Web Site: [www.accorroni.it](http://www.accorroni.it) - E-mail: [a2b@accorroni.it](mailto:a2b@accorroni.it)